



**Commercial**  
Water Softeners

**C43 & C47 Series 1-2" Softeners and Conditioners**

## **Installation Instructions & Owner's Manual**



[aosmith.com/commercialwatertreatment](http://aosmith.com/commercialwatertreatment)

# Table of Contents

Pre-Installation Instructions .....	3
Quick Reference Guide.....	4
Bypass Valve .....	6
Initial Controller Set-Up.....	7
Operating Displays and Maintenance .....	9
Troubleshooting Guide.....	11
Replacement Parts .....	14
Installation Fitting Assemblies .....	31
Warranty .....	33

SERVICING AGENT

PHONE NUMBER

Your A. O. Smith commercial water softeners and conditioners are precision built, high quality products. These units will deliver conditioned water for many years to come when installed and operated properly. Please study this manual carefully and understand the cautions and notes. This manual should be left at the installation site by the servicing agent to use as future reference by the system owner. If you have any questions regarding your water conditioner, contact your servicing agent.

# Pre-Installation

The manufacturer has preset the water treatment unit's sequence of cycles, cycle times, salt dose, exchange capacity and salt dose refill time.

## THE SERVICING AGENT MUST...

- Read this page and guide the installer regarding hardness, day override, time of regeneration, service alarm, and buzzer alarm settings prior to installation.
- Insert Servicing Dealer information on the table of contents in this manual.
- Fill out the Model Number, Serial Number, Water Hardness, and Time of Regen information below.
- Fill out the Model Number and Serial Number information on the warranty page of this manual.

## THE INSTALLER MUST...

- Confirm installer programming settings are correct.
- Read Operating Displays and Maintenance section.
- Set the time of day
- Read Power Loss and Error Display section.
- Ensure that system and installation are in compliance with all state and local laws and regulations

## PRODUCT INFORMATION

Servicing Agent must fill out this information prior to unit installation

INSTALLATION DATE \_\_\_\_\_

MODEL NUMBER \_\_\_\_\_

\*SERIAL NUMBER \_\_\_\_\_

WATER HARDNESS \_\_\_\_\_

TIME OF REGENERATION \_\_\_\_\_

## \*Serial Number Locations

1" to 1.25" Units

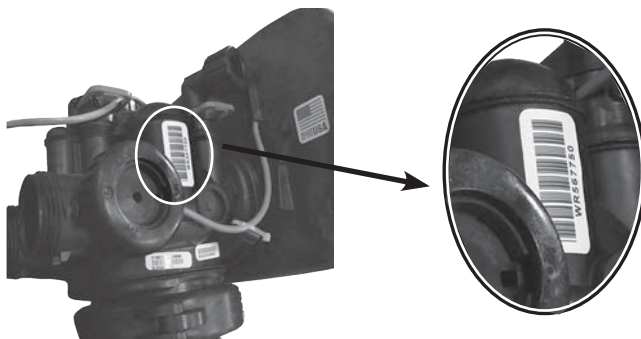

1.5" to 2" Units

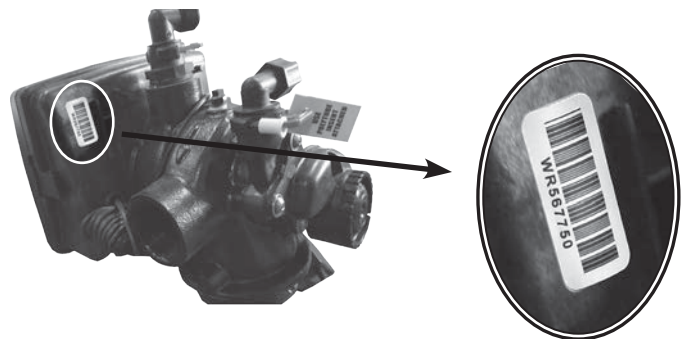

# Quick Reference Guide

## GENERAL OPERATION

When the system is operating, one of six displays will be shown:

Pressing **NEXT** will toggle between the six choices.

1. Time of day/gpm
2. Flow rate
3. Vacation mode
4. Capacity remaining
5. Days to a regen
6. Dealer name and phone number

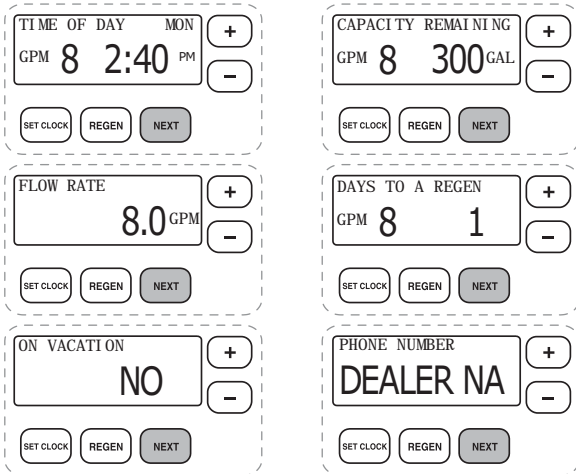

## TO SET TIME OF DAY

In the event of a prolonged power outage, time of day flashes, indicating that this needs to be reset. All other information will be stored in memory no matter how long the power outage.

1. Accessed by pressing **SET CLOCK**
2. Adjust hours with + and - buttons, AM/PM toggles at 12
3. Press **NEXT**
4. Adjust minutes with + and - buttons
5. Press **NEXT**
6. Adjust current day with + and - buttons
7. Press **NEXT** to complete and return to normal operation

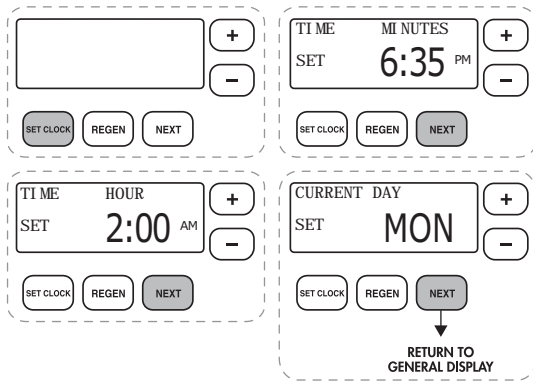

## MANUAL REGENERATION

If you need to initiate a manual regeneration, either immediately, or the same night at the preprogrammed time for regeneration (typically 2:00 AM), complete the following steps.

### For Immediate Regeneration:

Press and hold **REGEN** until valve motor starts (typically 3 seconds).

### For Regeneration the same night:

Press and release **REGEN** (notice that flashing "REGEN TODAY" appears).

REGEN TODAY and TIME OF DAY will flash alternately if a regeneration is expected tonight.

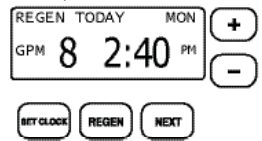

## ERROR

If the display toggles between "Error" and an error code (i.e. a number), call a service technician and report the error code.



## BYPASS VALVE OPERATION (1" & 1.25" ONLY)

To shut off water to the system, position arrow handles as shown in the bypass operation diagram below. If your valve doesn't look like the diagram below, contact your service technician for instructions on how to shut off water.

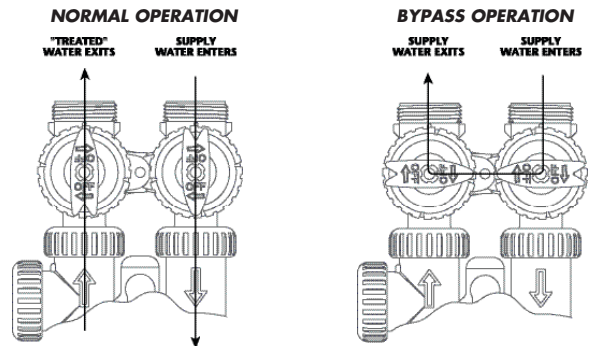

# Quick Reference Guide

## DEFAULT PROGRAMMING SETTINGS

For initial set-up or to make adjustments, please refer to Initial Controller Set-Up Section. Accessed by pressing and holding the **NEXT** and + buttons simultaneously. Press the **NEXT** button to advance to the next screen.

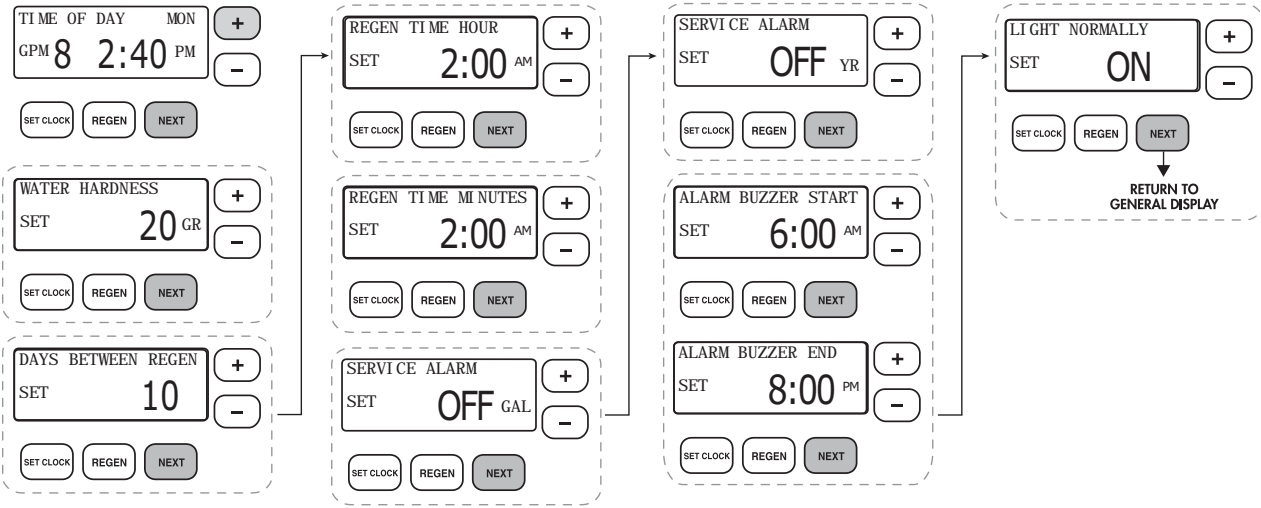

## TYPICAL INSTALLATION CONFIGURATIONS

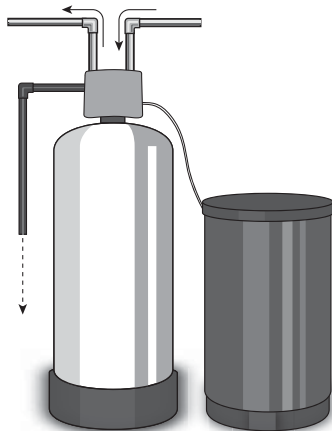

1" – 1.25" SINGLE

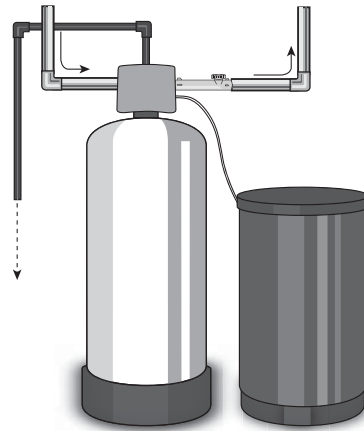

1.5" – 2.0" SINGLE

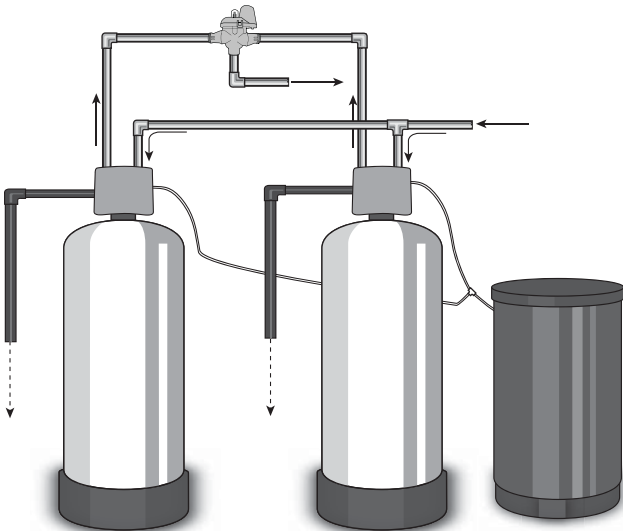

1" – 1.25" TWIN ALT

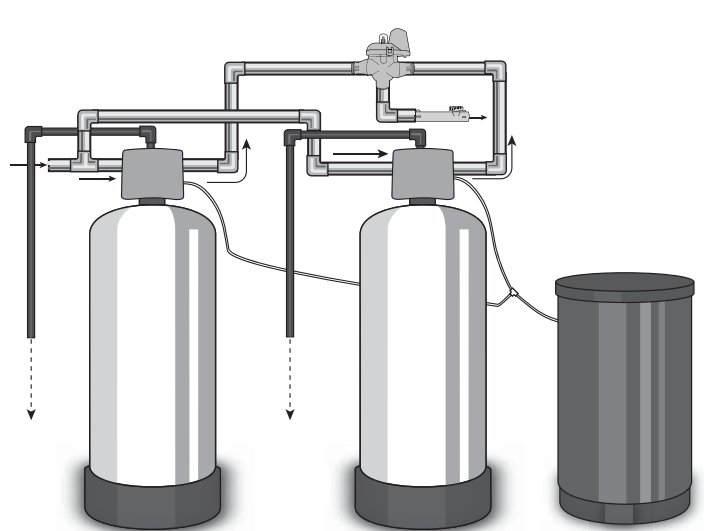

1.5" – 2.0" TWIN

# 1" – 1.25" Bypass Valve

The bypass valve is typically used to isolate the control valve from the plumbing system's water pressure in order to perform control valve repairs or maintenance. The 1" full flow bypass valve incorporates four positions, including a diagnostic position that allows a service technician to have pressure to test a system while providing untreated bypass water to the building. Be sure to install bypass valve onto main control valve, before beginning plumbing. Or, make provisions in the plumbing system for a bypass. The bypass body and rotors are glass-filled Noryl® and the nuts and caps are glass-filled polypropylene. All seals are self-lubricating EPDM to help prevent valve seizing after long periods of non-use. Internal "O" Rings can easily be replaced if service is required.

The bypass consists of two interchangeable plug valves that are operated independently by red arrow shaped handles. The handles identify the direction of flow. The plug valves enable the bypass valve to operate in four positions.

- 1. NORMAL OPERATION POSITION:** The inlet and outlet handles point in the direction of flow indicated by the engraved arrows on the control valve. Water flows through the control valve for normal operation of a water softener or filter. During the regeneration cycle this position provides regeneration water to the unit, while also providing untreated water to the distribution system (**Fig. 1**).
- 2. BYPASS POSITION:** The inlet and outlet handles point to the center of the bypass. The system is isolated from the water pressure in the plumbing system. Untreated water is supplied to the building (**Fig. 2**).
- 3. DIAGNOSTIC POSITION:** The inlet handle points toward the control valve and the outlet handle points to the center of bypass valve. Untreated supply water is allowed to flow to the system and to the building, while not allowing water to exit from the system to the building (**Fig. 3**). This allows the service technician to test the unit and perform other functions without disrupting the water going to the building.

**NOTE: The system must be rinsed before returning the bypass valve to the normal position.**

- 4. SHUT OFF POSITION:** The inlet handle points to the center of the bypass valve and the outlet handle points away from the control valve. The water is shut off to the building. The water treatment system will depressurize upon opening a tap in the building. A negative pressure in the building combined with the unit being in regeneration could cause a siphoning to the building. If water is available on the outlet side of the unit, it is an indication of water bypassing the system (**Fig. 4**) (i.e. a plumbing cross-connection somewhere in the building).

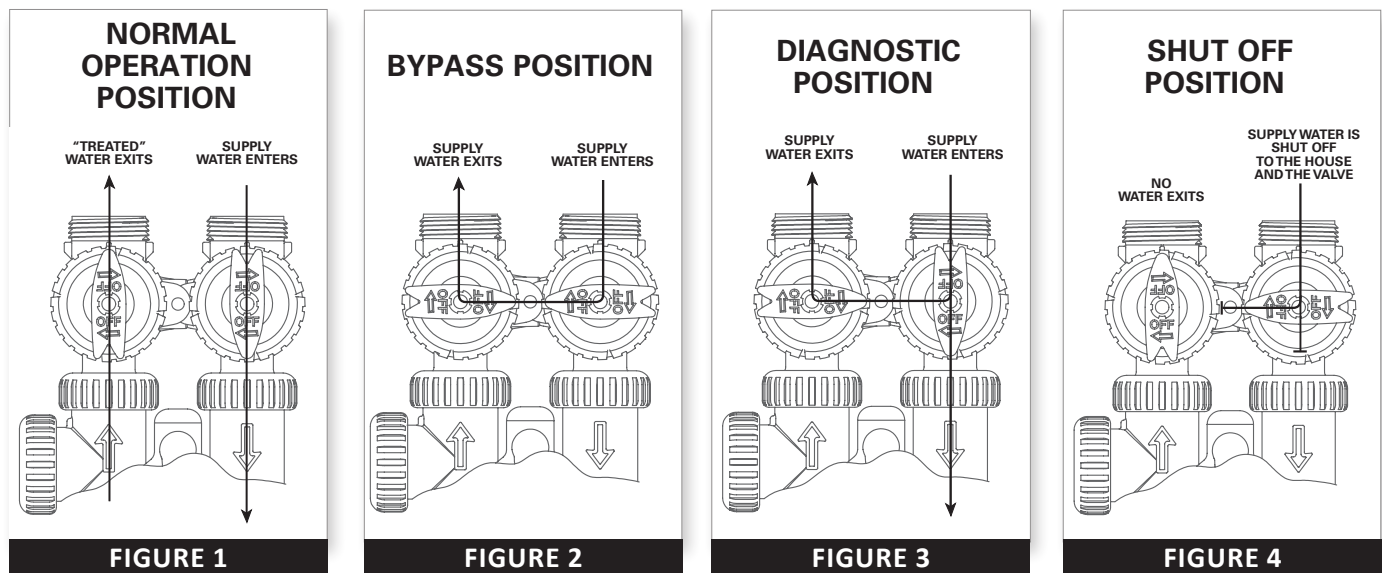

**Integrated Bypass valve available on 1" – 1.25" units only.**

# Initial Controller Set-Up

## 1. Set Time of Day

Typically, time of day should only need to be set after extended power outages or when daylight saving time begins or ends or after the battery has been replaced. If an extended power outage occurs, the time of day will flash on and off indicating that the time should be reset. To set the clock:

**STEP 1** – Press the **CLOCK** button.

**STEP 2** – Set the hour of the day using **+** or **-** buttons. AM/PM toggles after 12. Press **NEXT** to go to step 3.

**STEP 3** – Set the minutes using **+** or **-** buttons. Press **NEXT** to go to step 4 or **REGEN** to return to previous step.

**STEP 4** – Set the day of the week using **+** or **-** buttons. Press **NEXT** to exit clock setting or **REGEN** to return to previous step.

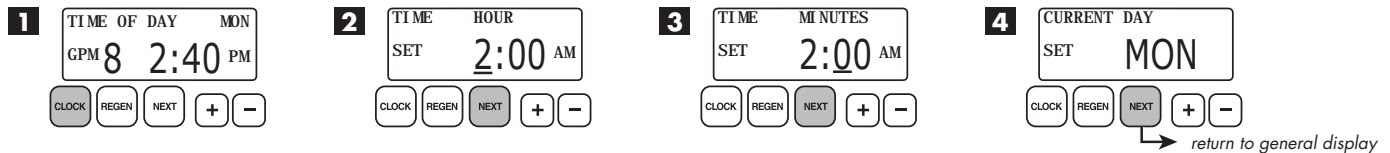

## 2. Programming

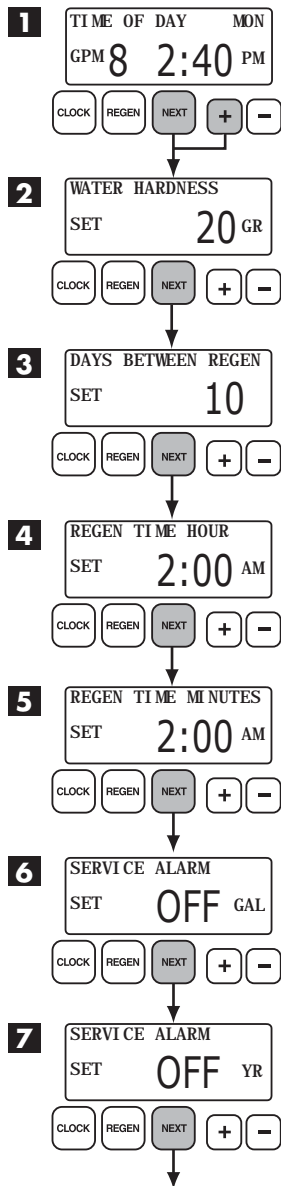

continued on next page

The manufacturer has preset the unit so that the gallons between regenerations will be automatically calculated after the hardness is entered. Press **NEXT** to cycle to the next step or **REGEN** to return to the previous step.

**STEP 1** – Press and hold the **NEXT** and **+** buttons simultaneously for 3 seconds.

**STEP 2 – HARDNESS:** Use the **+** or **-** buttons to adjust the hardness value in grains per gallons. Adjustable from 1 to 150 gpg in 1 grain increments (default setting is 20).

The hardness value is based on the actual compensated hardness of the water and must be set by an authorized dealer following an on-site water analysis. Adjusting the number will only impact the frequency of regeneration and will not alter or affect the hardness of the water treated by the unit.

**Note: If a resin media is used, increase the grains per gallon if soluble iron is present (1 ppm = 4 gpg). This screen will not display if "FILTER" mode is selected.**

**STEP 3 – DAYS BETWEEN REGENERATION (DAY OVERRIDE):** Use the **+** or **-** buttons to adjust the day override. Adjustable from 1-28 days or OFF. The manufacturer has factory set 10 days as the default.

The Day Override value represents the maximum number of days between regenerations. If any number is set (1-28 days), a regeneration will be scheduled for that day if the gallon capacity has not been met. If OFF is set, the unit will only initiate a regeneration once the gallon capacity has been met.

**STEP 4 – REGENERATION HOUR:** Use the **+** or **-** buttons to adjust the time of day the unit will regenerate. AM/PM toggles after 12. The manufacturer has factory set 2:00 A.M. as the default setting which is recommended for a normal household.

**STEP 5 – REGENERATION MINUTES:** Use the **+** or **-** buttons to set minutes.

**STEP 6 – SERVICE ALARM GALLONS:** Use the **+** or **-** buttons to schedule a service alarm by gallons. Adjustable in 100 gallon increments or OFF. The manufacturer has factory set OFF as the default.

This feature is typically set by the installing dealer to warn the homeowner that service is required after a number of gallons have been consumed. If the feature is active, a specific gallon amount will appear. For more information regarding how to set service alarms, the installer should consult the master programming guide that corresponds to the unit being installed.

Press the **NEXT** button three times to advance to the next screen.

**STEP 7 – SERVICE ALARM TIME:** Use the **+** or **-** buttons to schedule a service alarm in years. Adjustable in .25 year increments or OFF. The manufacturer has factory set OFF as the default.

This feature is typically set by the installing dealer to warn the homeowner that service is required after an amount of time has passed. If the feature is active, a specific number of days will appear. For more information regarding how to set service alarms, the installer should consult the master programming guide that corresponds to the unit being installed.

Press the **NEXT** button three times to advance to the next screen.

# Initial Controller Set-Up

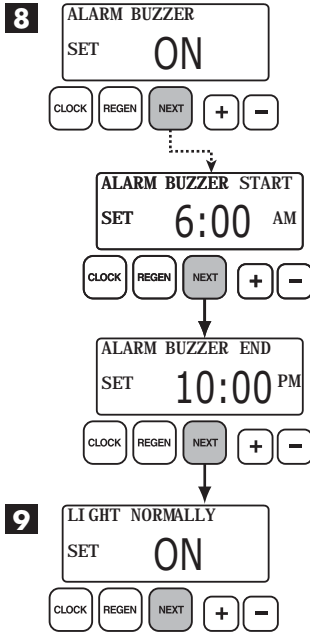

**STEP 8 – ALARM BUZZER:** Use the **+** or **-** buttons to turn the alarm ON or OFF. Unit is set to ON by default. Alarm will sound after a regeneration warning the owner of possible valve errors or other issues. This alarm is a short 0.5 second burst every 3 seconds. When alarm buzzer is set to ON, pressing the **NEXT** button proceeds to the Alarm Start Time screen. This feature allows the installer to choose a time when the owner will be home or awake to hear the alarm.

**BUZZER START TIME:** Press the **+** or **-** buttons to select the hour when the buzzer should begin sounding. AM/PM toggles after 12. Default setting is 6:00 a.m.

**BUZZER STOP TIME:** Press the **+** or **-** buttons to select the hour when the buzzer should stop sounding. AM/PM toggles after 12. Default setting is 10:00 p.m.

**STEP 9 – BACKLIGHT DISPLAY CONTROL:** Use the **+** or **-** buttons to turn the backlight setting ON or OFF. If unit is set to OFF, the backlight will turn off after 5 minutes of inactivity.

Press **NEXT** to return to General Display.

# Operating Displays & Maintenance

**1. GENERAL OPERATING DISPLAYS:** When the system is operating, one of six displays may be shown and will alternate with the installing dealer's name and phone number for future service. Pressing **NEXT** will alternate between the displays.

1. **Time of Day Screen:** Displays the current time of day, the day of the week, and flow rate.
2. **Flow Rate Screen:** Displays the current treated water flow rate through the system in Gallons Per Minute.
3. **Vacation Mode Screen:** This setting is not used in commercial applications.
4. **Capacity Remaining Screen:** Displays the amount of gallons of treated water remaining until the system triggers a regeneration.
5. **Days to a Regen Screen:** Displays the number of days until the system triggers a regeneration. Based on the days override value.
6. **Dealer Name Screen:** Displays dealer specific name and phone number. This scrolling display will only appear if set by the dealer.

\*In multi-valve installations, inactive units will display "StandBy" in the top-left corner of the screen.

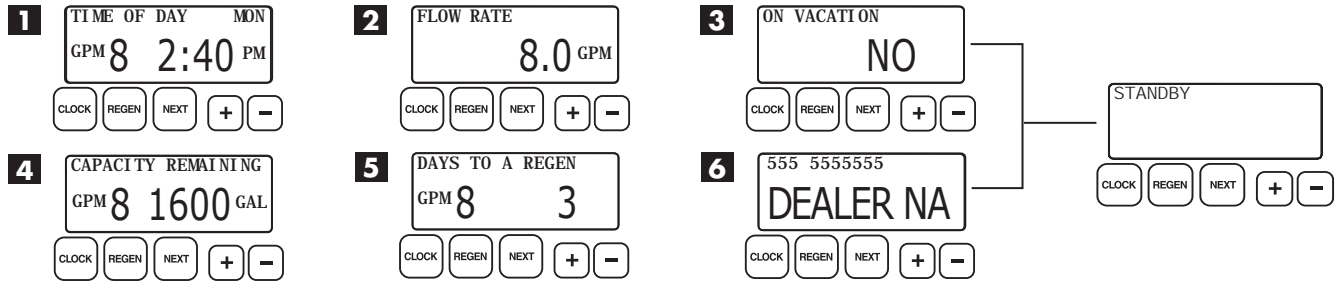

If the system has called for a regeneration that will occur at the preset time of regeneration, the words "REGEN TODAY" will appear on the display. If a water meter is installed, "GPM" flashes on the display when water is being treated, indicating gallons per minute flowing through the system.

## 2. GENERAL NAVIGATION

During normal operation, the default user displays are "time of day" and "gallons per minute". Flow rate, vacation mode, capacity remaining, and days to a regeneration are optional displays. For more explanation, consult the "operating displays and maintenance section". Pressing the **NEXT** button on a general operating screen will cycle through the available operating displays.

In any screen other than a general operating display, the **NEXT** button will proceed to the next step, the **REGEN** button will return to a previous step, and the **CLOCK** button will return to the general operating displays. Any changes made prior to the exit will be incorporated. If no buttons are pressed within five minutes, the display will return to the general operating displays.

**4. REGENERATION AND STANDBY DISPLAY:** Typically, a system is set to regenerate at a time of no water usage. If there is a demand for water when the system is regenerating, untreated water will be delivered. When the system begins to regenerate, the display will include information about the step of the regeneration process and the time remaining for that step to be completed. The system runs through the steps automatically and will reset itself to provide treated water when the regeneration has been completed.

In multi-valve installations, a unit will display "standby" in the top-left corner of the screen when it is inactive. The screen will return to a general operating display or a regeneration display once the unit is called back into service.

## 3. DOUBLE REGENERATION

Two generations within 24 hours are possible with a return to the preset program. To initiate a double regeneration:

1. Press the **REGEN** button once. "REGEN TODAY" will flash on the display.
2. Press and hold the **REGEN** button for three seconds until a regeneration begins.

Once the valve has completed the immediate regeneration, the valve will regenerate once more during the preset time.

**5. MANUAL REGENERATION:** Sometimes there may be a need to regenerate a unit before the control valve calls for it. This may be needed if a period of heavy water use is anticipated or when the system has been operating without salt.

- To initiate a manual regeneration at the next preset regeneration time, press and release the **REGEN** button. The words "REGEN TODAY" will flash on the display to indicate that the system will regenerate at the scheduled regeneration time (see the Programming Procedures section). If you pressed the **REGEN** button in error, pressing the button again will cancel the command.
- To initiate a manual regeneration immediately, press and hold the **REGEN** button for three seconds. The system will begin to regenerate immediately. **This command cannot be canceled.**

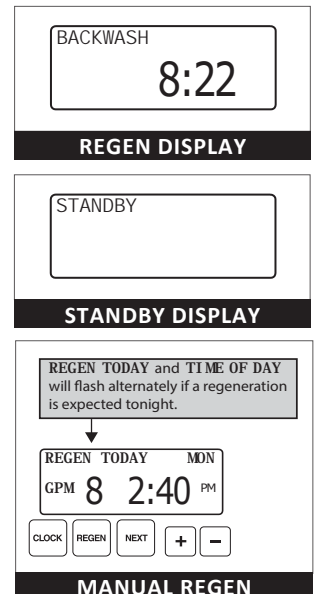

# Operating Displays & Maintenance

**6. POWER LOSS AND BATTERY REPLACEMENT:** If an extended power outage occurs, the control valve will retain the time of day settings until the board's battery is depleted. Once the battery is depleted, the display will appear dark and absent of any information. If this occurs, following these steps will determine if the problem is a low battery or a board failure.

To determine if the battery is depleted:

1. Remove valve cover. Disconnect power from PC Board at the four pin connector at the bottom of the board.
2. Remove battery. Reference the Parts Breakdown section of this manual for location.
3. Wait five minutes for board to de-energize.
4. With the battery out, re-connect the power supply to the board. The board's display should begin to show information.

**This indicates that the board is operating correctly. If the display does not work, call installing dealer for service.**

5. To replace with new battery, unplug transformer from outlet. Install a 3 volt Lithium Coin Cell type 2032 battery, available at most stores. Plug unit back into outlet.

**It is important to replace the battery with the valve unplugged to avoid causing a short and potentially ruining the board.**

6. Reset the time of day (see programming procedures) and initiate regeneration (see operating displays and maintenance).

**If these procedures do not remedy the problem, please consult the installing dealer for service.**

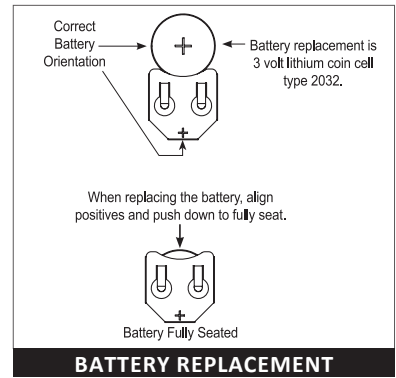

**7. ERROR MESSAGE:** If the word "ERROR" appears and flashes alternately with the dealer name and phone number, record the ERROR number and contact your servicing dealer promptly. This indicates that the control valve was not able to function properly.



**8. BRINE TANK MAINTENANCE AND SALT:** Refill the brine tank as necessary, making sure at least 1/3 of the brine tank is full at all times. Without proper salt levels, the water softener may not operate properly.

Because "typical" settings of this water softener include a dry salt storage feature (no water in brine tank between regeneration), the manufacturer recommends the use of solar salt for best results. The brine tank is manufactured for the use of solar, pellets or rock salt. **Do not use block salt.** If pellet or rock salt is used, a cleaning of the brine tank every six months is recommended. If the dry salt storage feature is not being utilized, block salt may be used.



**Caution:** With some models the manufacturer does NOT recommend the use of any resin cleaners, nor placing any resin cleaners into the brine tank. Furthermore, do not use any salt that indicates it is an iron cleaning salt or that contains any cleaning additives. This may be harmful to the water softener and for human consumption. Consult dealer for proper cleaning instructions.

**9. CHECK SALT INDICATOR AND AUDIBLE ALARM:** This control valve is equipped with a low salt warning to alert homeowners that the system is operating in a low salt condition. This usually indicated that the salt level in the brine tank is too low to operate properly. If "CHECK SALT" appears on the screen, there will usually be an audible alarm that sounds also (if turned on), alerting you to these conditions.



**TO TURN OFF ALARM:** If the audible alarm sounds due to a low salt condition, press any button on the face of the control valve to turn off. If the salt is not added to the brine tank before the next regeneration, the CHECK SALT indicator will alarm again.

# Troubleshooting Guide

ERROR	CAUSE
1. No display on PC board	A. Depleted battery
	B. Control valve power adapter not plugged into outlet or power cord end not connected to PC board connection
	C. Improper power supply
	D. Defective power adapter
	E. Defective PC board
	F. No power at electric outlet
2. PC board does not display correct time of day	A. Power adapter plugged into electric outlet controlled by light switch
	B. Tripped breaker switch and/or tripped GFI
	C. Power outage
	D. Defective PC board
3. Display does not indicate that water is flowing. Refer to user instructions for how the display indicates water is flowing.	A. Bypass valve in bypass position
	B. Meter is not connected to meter connection on PC board
	C. Restricted/stalled meter turbine
	D. Meter wire not installed securely into three pin connector
	E. Defective meter
	F. Defective PC board
4. Control valve regenerates at wrong time of day	A. Power outage
	B. Time of day not set correctly
	C. Time of regeneration set incorrectly
	D. Control valve set at "on 0" (immediate regeneration)
	E. Control valve set at "NORMAL + on 0" (delayed and/or immediate)
5. Time of day flashes on and off	A. Power outage
6. Control valve does not regenerate automatically when the correct button(s) is depressed and held. For timeclock valves the buttons are ▲ & ▼. For all other valves the button is REGEN.	A. Broken drive gear or drive cap assembly
	B. Broken piston rod
	C. Defective PC board
	D. Cover installed incorrectly
7. Control valve does not regenerate automatically but does when the correct button(s) is depressed and held. For timeclock valves the buttons are ▲ & ▼. For all other valves the button is REGEN.	A. Bypass valve in bypass position
	B. Meter is not connected to meter connection on PC board
	C. Restricted/stalled meter turbine
	D. Incorrect programming
	E. Meter wire not installed securely into three pin connector
	F. Defective meter
	G. Defective PC board
8. Hard or untreated water is being delivered	A. Bypass valve is open or faulty
	B. Media is exhausted due to high water usage
	C. Meter not registering
	D. Water quality fluctuation
	E. No regenerant or low level of regenerant in regenerant tank
	F. Control fails to draw in regenerant
	G. Insufficient regenerant level in regenerant tank
	H. Damaged seal/stack assembly
	I. Control valve body type and piston type mix matched
	J. Fouled media bed
9. Control valve uses too much regenerant	A. Improper refill setting
	B. Improper program settings
	C. Control valve regenerates frequently

# Troubleshooting Guide

ERROR	CAUSE
10. Residual regenerant being delivered to service	A. Low water pressure
	B. Incorrect, damaged, or restricted injector
	C. Restricted drain line
11. Excessive water in regenerant tank	A. Improper program settings
	B. Plugged injector
	C. Drive cap assembly not tightened in properly
	D. Damaged seal/stack assembly
	E. Restricted or kinked drain line
	F. Plugged backwash flow controller
	G. Missing refill flow controller
12. Control valve fails to draw in regenerant	A. Injector is plugged
	B. Faulty regenerant piston
	C. Regenerant line connection leak
	D. Drain line restriction or debris cause excess back pressure
	E. Drain line too long or too high
	F. Low water pressure
13. Water running to drain	A. Power outage during regeneration
	B. Damaged seal/stack assembly
	C. Piston assembly failure
	D. Drive cap assembly not tightened in properly
14. E1, Err – 1001, Err – 101 = Control unable to sense motor movement	A. Motor not inserted full to engage pinion, motor wires broken or disconnected
	B. PC board not properly snapped into drive bracket
	C. Missing reduction gears
15. E2, Err – 1002, Err – 102 = Control valve motor ran too short and was unable to find the next cycle position and stalled	A. Foreign material is lodged in control valve
	B. Mechanical binding
	C. Main drive cap too tight
	D. Improper voltage being delivered to PC board
16. E3, Err – 1003, Err – 103 = Control valve motor ran too long and was unable to find the next cycle position	A. Motor failure during a regeneration
	B. Foreign matter built up on piston and stack assemblies creating friction and drag enough to time out motor
	C. Drive bracket not snapped in properly and out enough that reduction gears and drive gear do not interface
17. E4, Err – 1004, Err – 104 = Control valve motor ran too long and timed out trying to reach home position	A. Drive bracket not snapped in properly and out enough that reduction gears and drive gear do not interface
18. Err – 1006, Err – 106, Err – 116 = MAV/ SEPS/ NHBP/ AUX MAV valve motor ran too long and unable to find the proper park position  Motorized Alternating Valve = MAV Separate Source = SEPS No Hard Water Bypass = NHBP Auxiliary MAV = AUX MAV	A. Control valve programmed for ALT A or B, nHBP, SEPS, or AUX MAV without having a MAV or NHBP valve attached to operate that function
	B. MAV/NHBP motor wire not connected to PC board
	C. MAV/NHBP motor not fully engaged with reduction gears
	D. Foreign matter built up on piston and stack assemblies creating friction and drag enough to time out motor
19. Err – 1007, Err – 107, Err – 117 = MAV/ SEPS/NHBP/ AUX MAV valve motor ran too short (stalled) while looking for proper park position  Motorized Alternating Valve = MAV Separate Source = SEPS No Hard Water Bypass = NHBP .Auxiliary MAV = AUX MAV	A. Foreign material is lodged in MAV/NHBP valve
	B. Mechanical binding

# Troubleshooting Guide

ERROR	CAUSE
20. Err – 109	A. Invalid motor state detected
21. Err – 201	A. Invalid regeneration cycle step detected
22. Err – 204 = Leak detected	A. Occurs when dP input is active for “ALARM” and the input is closed. The alarm buzzer will activate and the screen will display the error.
23. Err – 400* Memory Errors *(All 400 errors pertain to memory related errors)	A. Depleted Battery B. Defective PC Board

# Replacement Parts

FRONT COVER AND DRIVE ASSEMBLY			
Item #	Part #	Description	Qty.
1	CV3540-NOLAB	Black cover	1
2	CV3107-01	Motor Assembly	1
3	CV32002-A	Drive assembly (includes #5 and #6)	-
4	CV3502WE	PC board (used on chlorine generator models)	1
	CV4022WU	PC board (standard)	1
5	CV3110	Drive gear, 12 x 36	3
6	CV3109	Drive gear cover	1
not shown	CV3526	Transformer, 110V-15V, DC (used on chlorine generator models)	1
	CV3186	Transformer, 110V-12V, AC (standard)	1
	CV3543	Optional weather cover	1
	CV4276-15	System controller power cord, 15 foot	1
	CV4276-36	System controller power cord, 36 foot	1

**NOTE: Battery Location**

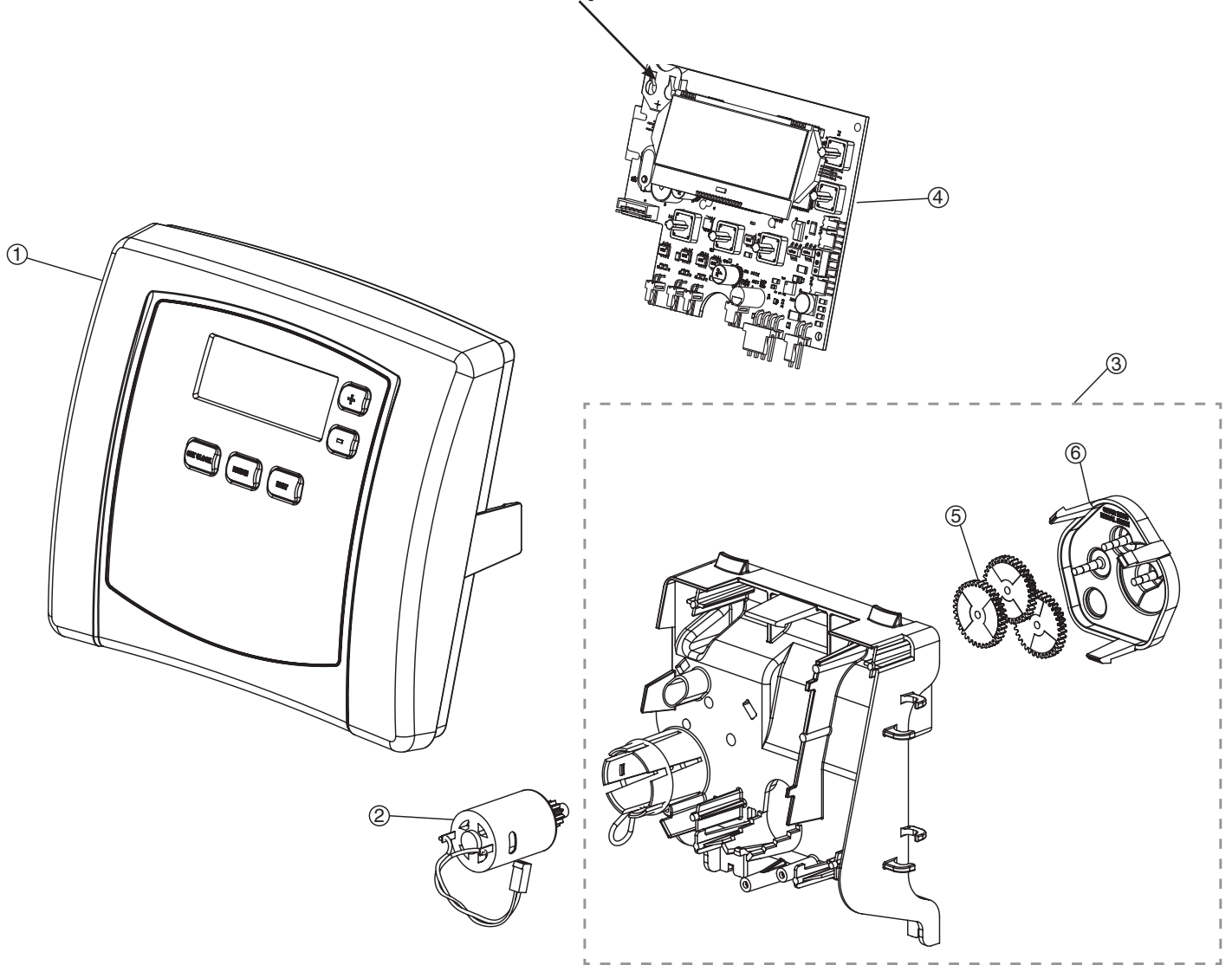

# Replacement Parts

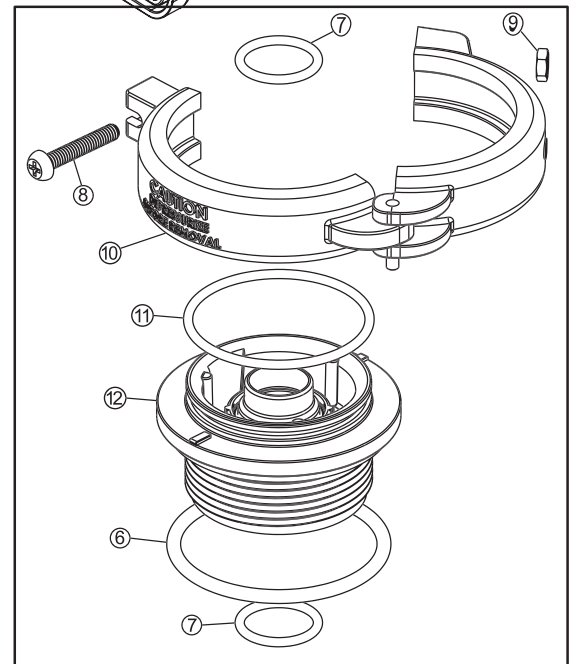
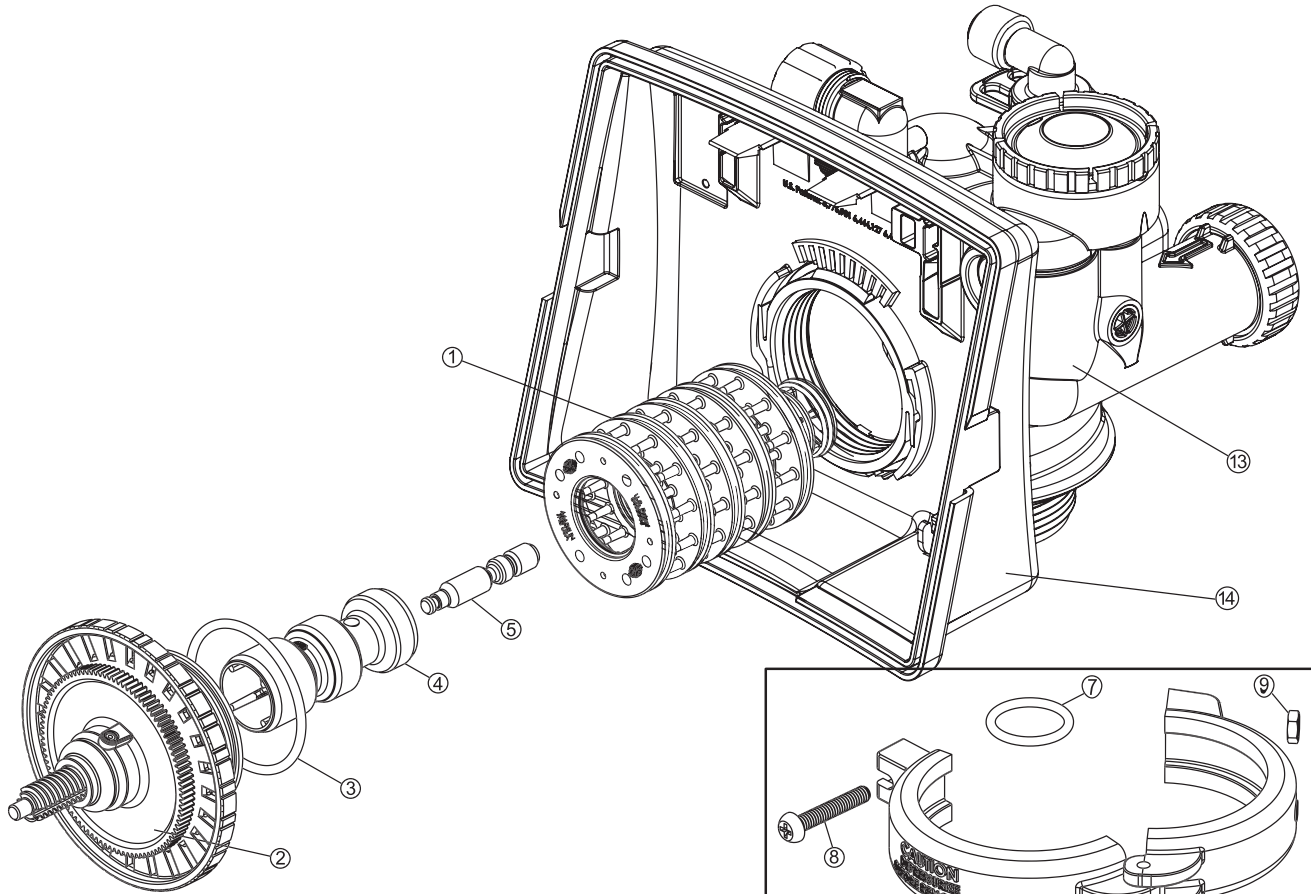

**QC Adapter on 1" Versions  
Only**

PISTON ASSEMBLY			
Item #.	Part #	Description	Qty.
1	CV3005-02	1" spacer stack assembly	1
	CV3430-01	1.25" and 1.5" spacer stack assembly	1
2	CV3004	Drive cap assembly	1
3	CV3135	O-ring 228 (drive cap o-ring)	1
4	CV3011	1" piston assembly downflow	1
	CV3011-01	1" piston assembly upflow	1
	CV3407	1.25" and 1.5" downflow piston assembly	1
5	CV3174	Regenerant piston	1
6	CV3180	O-ring 337	1
7	CV3105	O-ring 215	1
8	CV3556	Screw, 1/4 - 20x1-1/2 18-8SS	1
9	CCI-00318337	Nut, 1/4 - 20 HEX 18-8SS	1
10	CV3016	QC2 clamp assembly (includes screw & nut)	1
11	CV3452	O-ring 230 (tank flange o-ring)	1
12	CV3015	Quick Connect Tank Adaptor	1
13	CV3001-04	1" body assembly downflow	1
	CV3020	1.25" body assembly downflow	1
14	CV3541	Drive backplate	1

# Replacement Parts

1.5" VALVE BODY ASSEMBLY			
Item #	Part #	Description	Qty.
1	CV3004	Drive Cap Assembly	1
2	CV3135	O-ring 228 (drive cap o-ring)	1
3	CV3407	1.25" and 1.5" downflow piston assembly	1
4	CV3174	Regenerant Piston	1
5	CV3423	1.5 Backplate Dowel	1
6	CV3430-01	1.25" and 1.5" spacer stack assembly	1
7	CV3541	Drive Backplate	1
8	CV3419	O-Ring 347	1
9	CV3641	O-Ring 328	1
10	CV3950-01	1.5 Valve Body Downflow	1

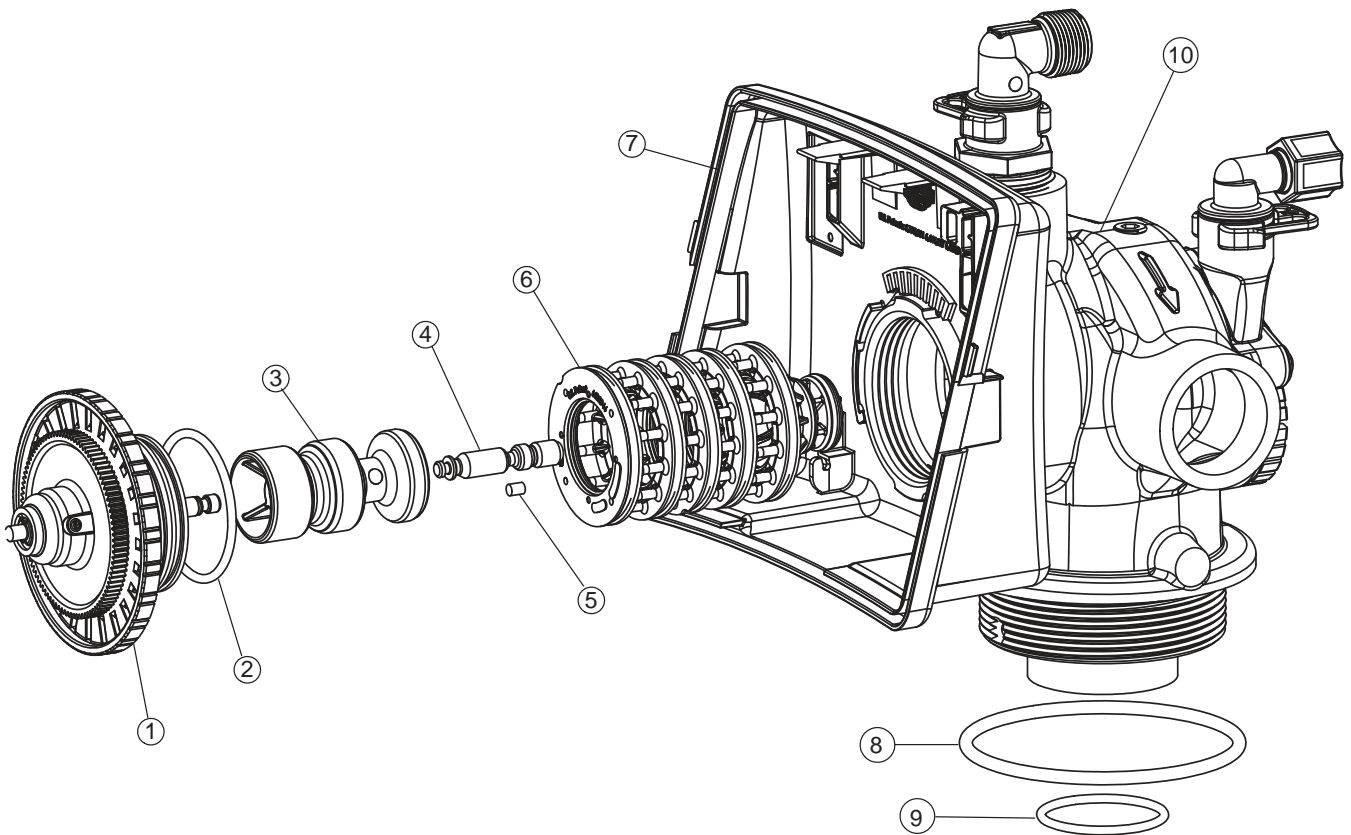

# Replacement Parts

2" VALVE BODY ASSEMBLY			
Item #	Part #	Description	Qty.
1	CV3726	WS2 Brine Piston Assembly	1
2	CV3725	WS2 Piston Downflow Assembly	1
3	CV3452	O-ring 230 (tank flange o-ring)	1
4	CV3728	WS2 Drive Cap Assembly	1
5	CV3724	Washer, Flat SS 1/4	1
6	CV3642	Bolt, BHCS S/S 1/4-20 X 1.25	1
7	CV3541	Drive Backplate	1
8	CV3729	WS2 Stack Assembly	1
9	CV3419	O-Ring 347 for WS15	1
10	CV3641	O-Ring 225 (for bodies with NPT threads)	1
11	CV3700-01	WS2 Body, NPT	1
not shown	CV3468	WS2H Plug, 1/4 Hex NPT	1
	CD1300-01	Top Baffle DFSR Clack 1.5/50mm	1

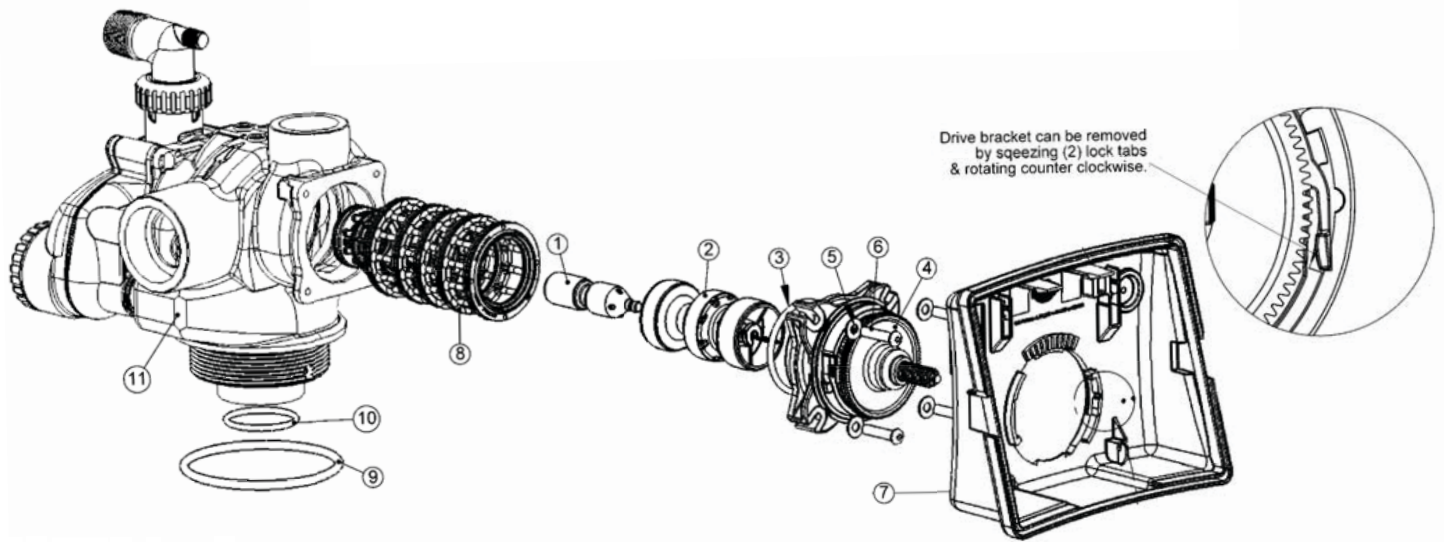

# Replacement Parts

BYPASS VALVE			
Item #	Part #	Description	Qty.
1	CV3006	Bypass assembly	1
2	CV3147	Bypass handles	2

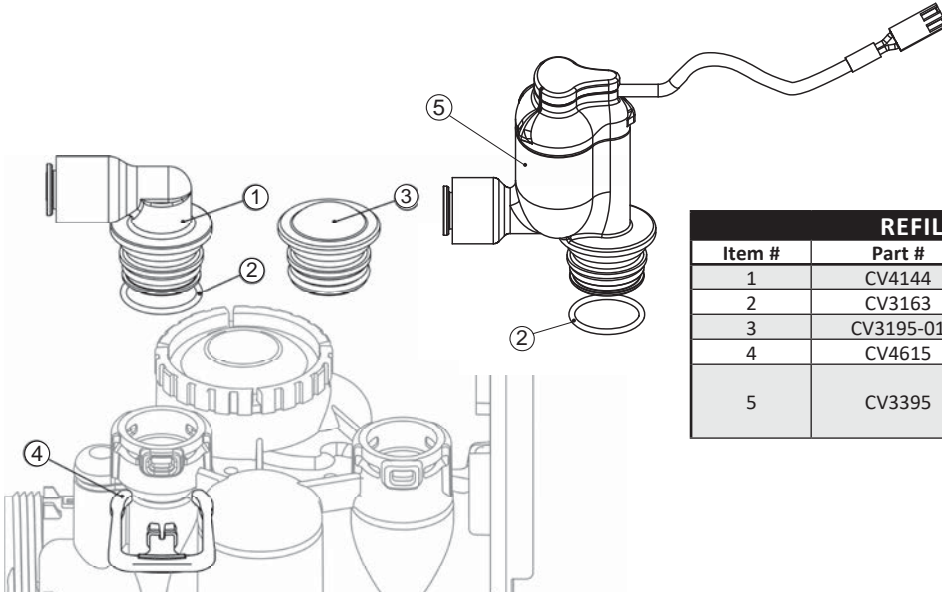
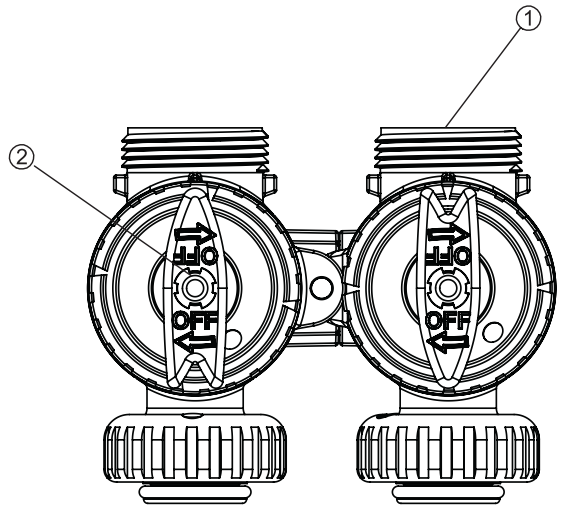

REFILL PORT ASSEMBLY			
Item #	Part #	Description	Qty.
1	CV4144	3/8" Elbow, Parker fitting	1
2	CV3163	O-ring 019	1
3	CV3195-01	Refill port plug assembly	1
4	CV4615	Elbow locking clip	1
5	CV3395	Chlorine Generator (Black) *Only available on 1" and 1.25" valves on 16" or smaller tanks	1

## SERVICE WRENCH - CV3193-02

Although no tools are necessary to assemble or disassemble the valve, the Service Wrench, (shown in various positions on the valve) is available to aid in assembly or disassembly.

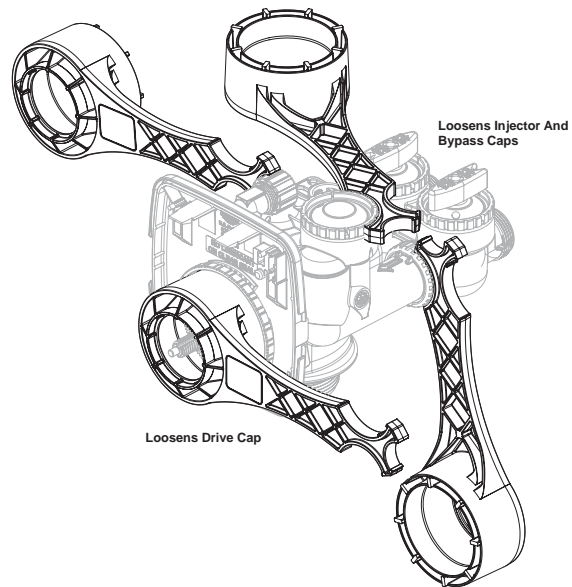

# Replacement Parts

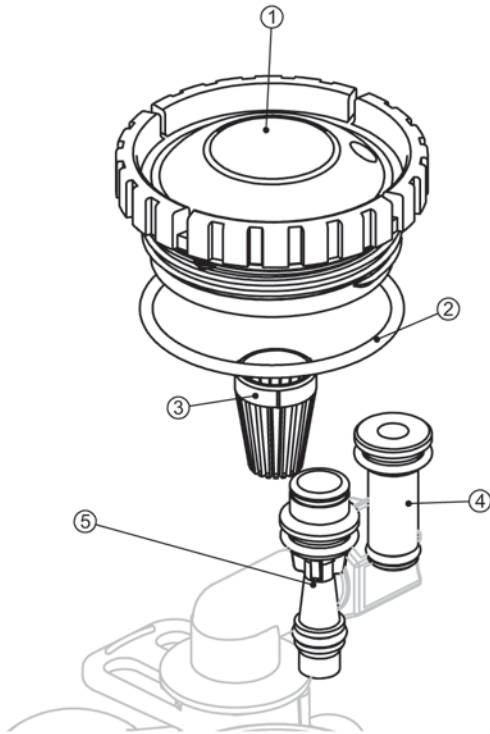

1" INJECTOR ASSEMBLIES			
Item #	Part #	Description	Qty.
1	CV3176	Injector cap	1
2	CV3152	O-ring 135	1
3	CV3177-01	Injector screen	1
4	CV3010-1Z	Injector assembly plug	1
5	CV3010-1A	A injector assembly, black	1
	CV3010-1B	B injector assembly, brown	
	CV3010-1C	C injector assembly, violet	
	CV3010-1D	D injector assembly, red	
	CV3010-1E	E injector assembly, white	
	CV3010-1F	F injector assembly, blue	
	CV3010-1G	G injector assembly, yellow	
	CV3010-1H	H injector assembly, green	
	CV3010-1I	I injector assembly, orange	
	CV3010-1J	J injector assembly, light blue	
CV3010-1K	K injector assembly, light green		
not shown	CV3170	O-ring O11, lower	*
not shown	CV3171	O-ring O13, upper	*

\*The injector plug and the injector each use one lower and one upper o-ring

1.5" INJECTOR ASSEMBLIES			
Item #	Part #	Description	Qty.
1	CV3967	WS1.5 Injector Body, Welded Assembly	1
2	CV3441	O-Ring 226	1
3	CV3968	WS1.5 Injector Feed Tube Dnflw, BLK	1
	CV3968-01	WS1.5 Injector Feed Tube Upflw, Gray	
4	CV3177-01	WS1 Injector Screen	1
5	CV3969	WS1.5 Injector Draw Tube Dnflw, Black	1
	CV3969-01	WS1.5 Injector Draw Tube Upflw, Gray	
6	CV3176	WS1 Injector Cap	1
7	CV3152	O-Ring 135	1
8	CV3010-15B	WS1.5 Injector Assembly B	1
	CV3010-15C	WS1.5 Injector Assembly C	
	CV3010-15D	WS1.5 Injector Assembly D	
	CV3010-15E	WS1.5 Injector Assembly E	
	CV3010-15F	WS1.5 Injector Assembly F	
	CV3010-15G	WS1.5 Injector Assembly G	
	CV3010-15H	WS1.5 Injector Assembly H	
	CV3010-15I	WS1.5 Injector Assembly I	
	CV3010-15Z	WS1.5 Injector Plug	
9	CV3498	Refill Flow Control 1/2"	1
10	CV3428	WS 1.5 Refill Retainer Assembly (.5 GPM)	1
11	CV3163	O-Ring O19	1
12	CH4612	Regenerant Elbow with Flow Control	1
13	CJCPG-8PBLK	Nut, Compression 1/2" Black	1
14	CJCP-P-8	Insert, Polytube 1/2"	1
15	CV3182	Refill Flow Control (0.5 GPM)	1
16	CH4615	Retaining Clip	1
17	CV3724	Washer, Flat Stainless Steel	1
18	CV3642	Bolt, BHCS Stainless Steel	1
19	CV3195-01	Refill Port Plug	1

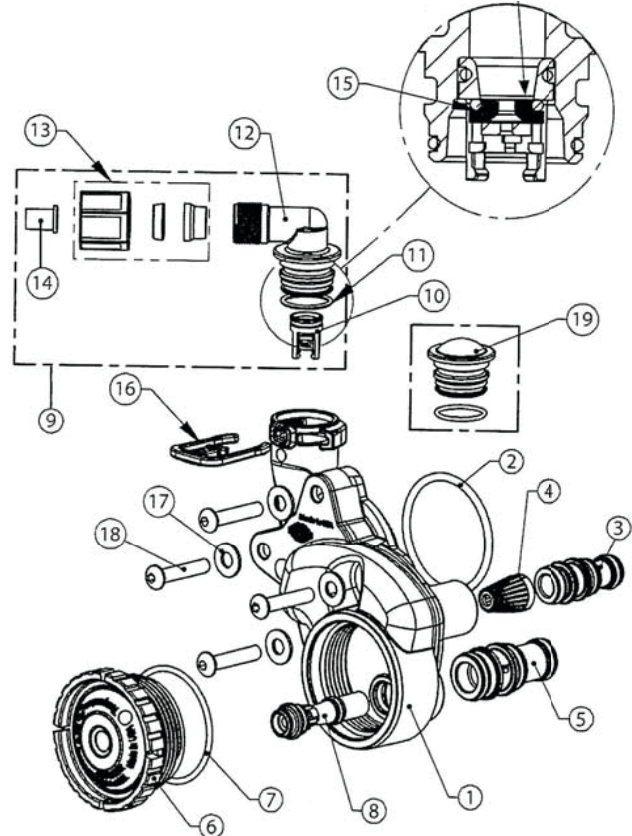

# Replacement Parts

2" INJECTOR ASSEMBLIES			
Item #	Part #	Description	Qty.
1	CV3477	WS2H Injector Cap	1
2	CV3152	O-Ring 135	1
3	CV3727	WS2 Injector Body Assembly	1
4	CV3010-2R-15B	WS2/2H INJ R Assembly W/CV3010-15B	1
	CV3010-2S-15C	WS2/2H INJ S Assembly W/CV3010-15C	1
	CV3010-2T-15D	WS2/2H INJ T Assembly W/CV3010-15D	1
	CV3010-2U-15E	WS2/2H INJ U Assembly W/CV3010-15E	1
	CV3010-2V-15F	WS2/2H INJ V Assembly W/CV3010-15F	1
	CV3010-2W-15G	WS2/2H INJ W Assembly W/CV3010-15G	1
	CV3010-2X-15H	WS2/2H INJ X Assembly W/CV3010-15H	1
	CV3010-2A	WS2/2H Injector Assembly A	1
	CV3010-2B	WS2/2H Injector Assembly B	1
	CV3010-2C	WS2/2H Injector Assembly C	1
	CV3010-2D	WS2/2H Injector Assembly D	1
	CV3010-2E	WS2/2H Injector Assembly E	1
	CV3010-2F	WS2/2H Injector Assembly F	1
CV3010-2G	WS2/2H Injector Assembly G	1	
5	CV3731	WS2 Injector Draw Tube, Dwn Assembly	1
6	CV3730	WS2 Injector Feed Tube, Dwn Assembly	1
7	CV3315	O-Ring 231	1
8	CV3724	Washer Flat SS 1/4	1
9	CV3643	Bolt BHCS S/S 1/4-20 x 2.25	1
10	CV3162-022	WS1 DLFC022-3/4	1
11	CV3231	WS2H Refill Flow Control Retainer	1
12	CV3277	O-Ring 211	1
13	CV3105	O-Ring 215	1
14	CV3150	WS1 Split Ring	1
15	CV3151	WS1 Nut 1 QC	1
16	CV3149	WS1 FTG 1 PVC Male NPT Elbow	1

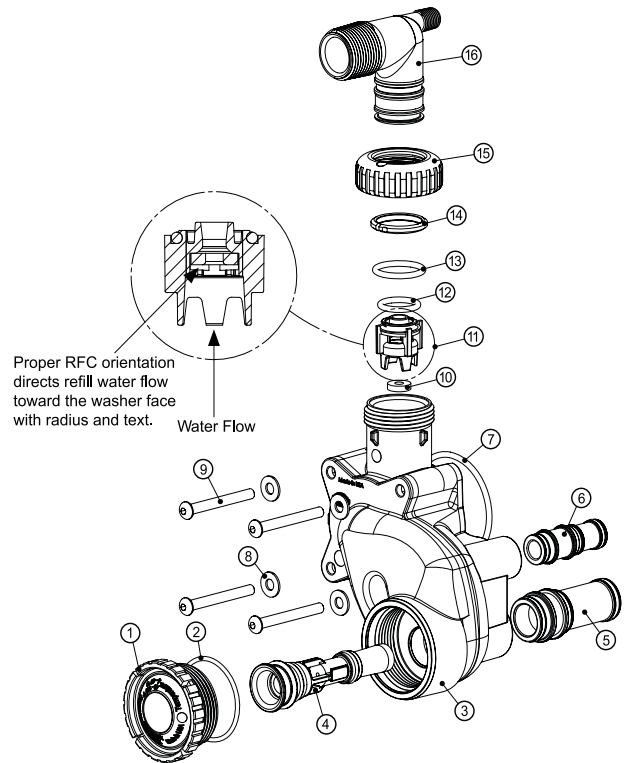

WATER METER AND METER PLUG			
Item #	Part #	Description	Qty.
1	CV3151	Nut, 1" QC	1
2	CV3003	Meter assembly, includes items 3 & 4	1
3	CV3118-01	Turbine assembly	1
4	CV3105	O-ring 215	1
5	CV3003-01	Meter plug assembly	1

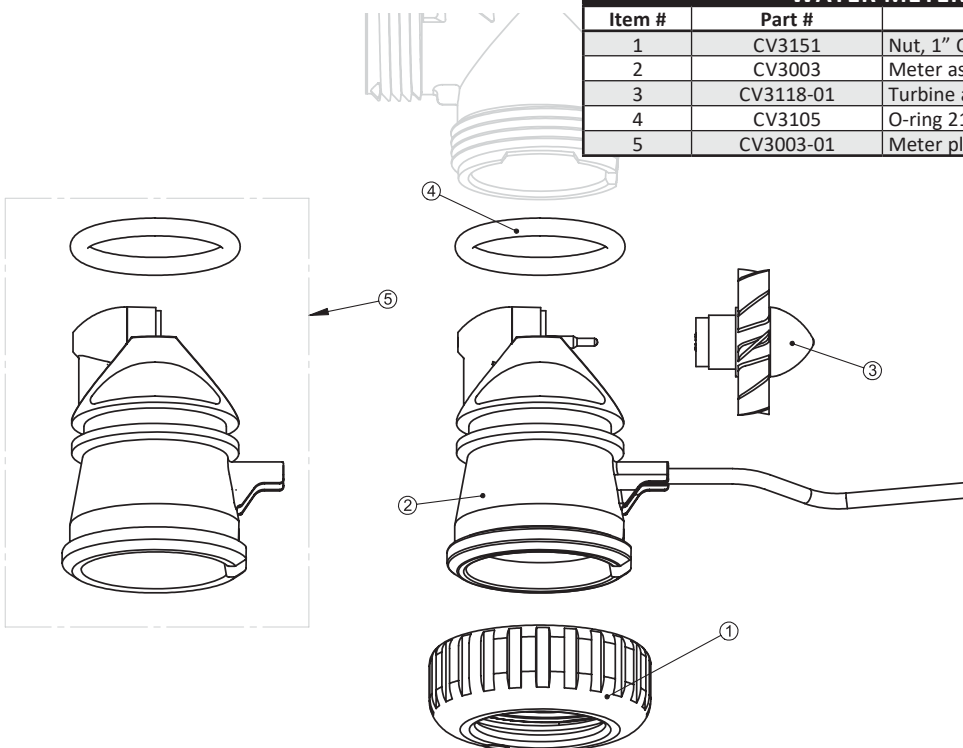

# Replacement Parts

DRAIN LINE ASSEMBLY 3/4"			
Item #	Part #	Description	Qty.
1	CH4615	Elbow locking clip	1
2	CPKP10TS8-BULK	Optional insert, 5/8" tube	1
3	CV3192	Optional nut, 3/4" drain elbow	1
4	CV3158-02	Drain elbow, 3/4" NPT with O-ring	1
5	CV3163	O-ring 019	1
6	CV3159-01	DLFC retainer assembly	1
7	CV3162-007	0.7 DLFC for 3/4" elbow	1
	CV3162-010	1.0 DLFC for 3/4" elbow	
	CV3162-013	1.3 DLFC for 3/4" elbow	
	CV3162-017	1.7 DLFC for 3/4" elbow	
	CV3162-022	2.2 DLFC for 3/4" elbow	
	CV3162-027	2.7 DLFC for 3/4" elbow	
	CV3162-032	3.2 DLFC for 3/4" elbow	
	CV3162-042	4.2 DLFC for 3/4" elbow	
	CV3162-053	5.3 DLFC for 3/4" elbow	
CV3162-065	6.5 DLFC for 3/4" elbow		
CV3162-075	7.5 DLFC for 3/4" elbow		
8	CV3331	Drain elbow and retainer assembly	

DRAIN LINE ASSEMBLY 1"			
Item #	Part #	Description	Qty.
1	CH4615	Elbow locking clip	1
2	CV3166	Drain FTG body 1	1
	CV3166-01	FTG flow control body 1	
3	CV3167	Drain FTG adapter 1	1
4	CV3163	O-ring 019	1
5	CV3150	Split ring	1
6	CV3151	Nut 1" QC	1
7	CV3105	O-ring 215	
8	CV3190-090	9.0 gpm DLFC for 1" elbow	One DLFC must be used if 1" fitting is used
	CV3190-100	10.0 gpm DLFC for 1" elbow	
	CV3190-110	11.0 gpm DLFC for 1" elbow	
	CV3190-130	13.0 gpm DLFC for 1" elbow	
	CV3190-150	15.0 gpm DLFC for 1" elbow	
	CV3190-170	17.0 gpm DLFC for 1" elbow	
	CV3190-200	20.0 gpm DLFC for 1" elbow	
CV3190-250	25.0 gpm DLFC for 1" elbow		
9	CV3008-04	FTG Drain 1" Strt No/Sil	1

Items 2 and 3, nut and insert are only used with 1/2" I.D. by 5/8" O.D. polytubing. For other piping material, the 3/4" NPT is used.

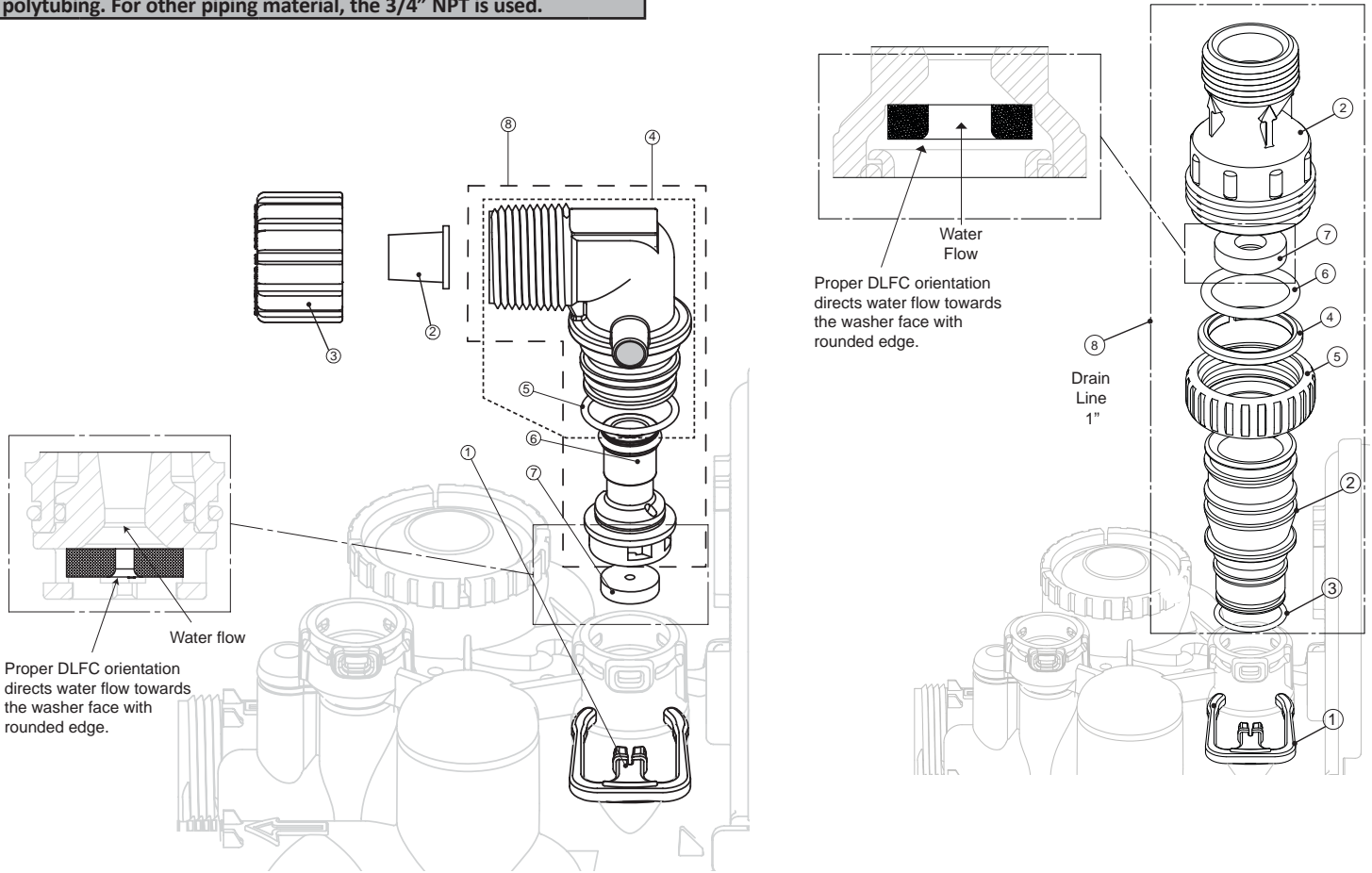

# Replacement Parts

DRAIN LINE ASSEMBLY 1.25" AND 1.5"			
Item #	Part #	Description	Qty.
1	CV3081	WS15 RETAINER DLFC ASSEMBLY	1
2	CV3645	WS15 DLFC FLANGE OUTLET FNPT	1
3	CV3646	WS15 DLFC FLANGE INLET MNPT	1
4	CV3647	WS125 DLFC FLANGE INLET MNPT	1
5	CV3652	BOLT, HEX HD, 5/16 - 18 x 3/4	1
6	CV3441	O-RING, 226	1
NOT SHOWN (install one CV3190-XXX in center hole; knock out plugs allow installation of up to 6 more of CV3162-XXX)	CV3162-007	WS1 DLFC 0.7 GPM FOR 3/4	1
	CV3162-010	WS1 DLFC 1.0 GPM FOR 3/4	1
	CV3162-013	WS1 DLFC 1.3 GPM FOR 3/4	1
	CV3162-017	WS1 DLFC 1.7 GPM FOR 3/4	1
	CV3162-022	WS1 DLFC 2.2 GPM FOR 3/4	1
	CV3162-027	WS1 DLFC 2.7 GPM FOR 3/4	1
	CV3162-032	WS1 DLFC 3.2 GPM FOR 3/4	1
	CV3162-042	WS1 DLFC 4.2 GPM FOR 3/4	1
	CV3162-053	WS1 DLFC 5.3 GPM FOR 3/4	1
	CV3162-065	WS1 DLFC 6.5 GPM FOR 3/4	1
	CV3162-075	WS1 DLFC 7.5 GPM FOR 3/4	1
	CV3162-090	WS1 DLFC 9.0 GPM FOR 3/4	1
	CV3162-100	WS1 DLFC 10.0 GPM FOR 3/4	1
	CV3190-090	WS1 DLFC 9.0 GPM FOR 1	1
	CV3190-100	WS1 DLFC 10.0 GPM FOR 1	1
	CV3190-110	WS1 DLFC 11.0 GPM FOR 1	1
	CV3190-130	WS1 DLFC 13.0 GPM FOR 1	1
	CV3190-150	WS1 DLFC 15.0 GPM FOR 1	1
	CV3190-170	WS1 DLFC 17.0 GPM FOR 1	1
	CV3190-200	WS1 DLFC 20.0 GPM FOR 1	1
CV3190-250	WS1 DLFC 25.0 GPM FOR 1	1	
7	CV3079	WS DLFC 1.25 x 1.5 ASSEMBLY	1
8	CV3080	WS DLFC 1.5 x 1.5 ASSEMBLY	1

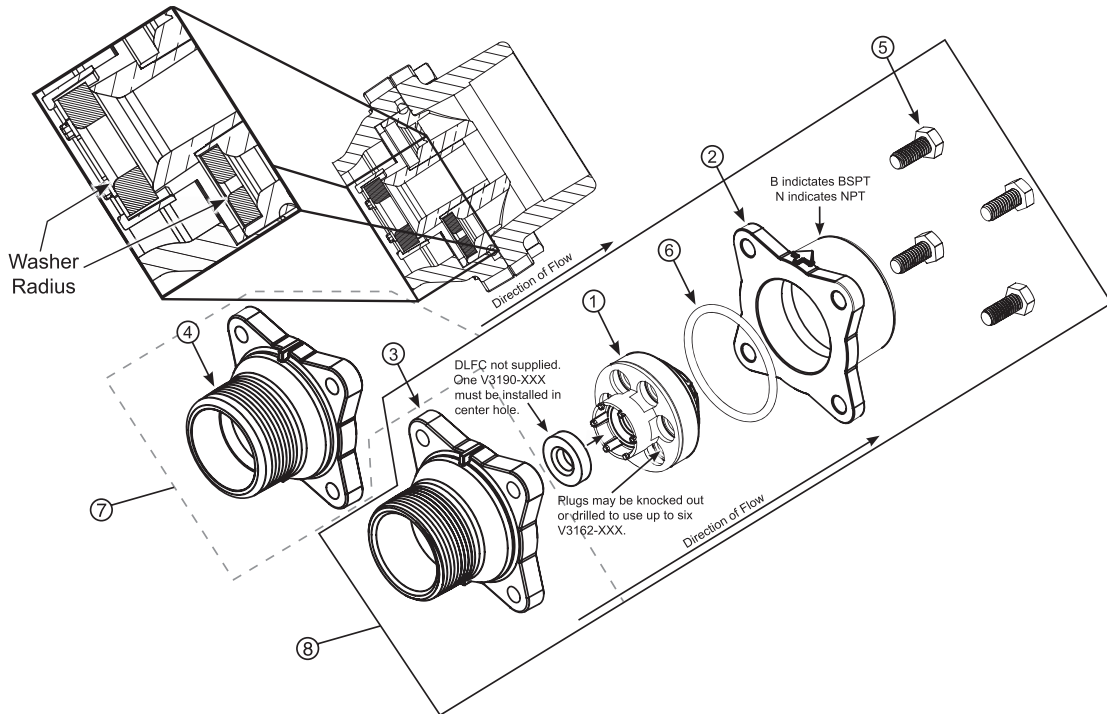

# Replacement Parts

## DRAIN LINE ASSEMBLY 2"

Item #	Part #	Description	Qty.
1	CV3052	WS15 RETAINER DLFC ASSEMBLY	1
2	CV3245	WS15 DLFC FLANGE OUTLET FNPT	1
3	CV3246	WS15 DLFC FLANGE INLET MNPT	1
4	CV3273	WS125 DLFC FLANGE INLET MNPT	1
5	CV3441	O-RING, 338	1
NOT SHOWN (Install one or more DLFC washer. Up to 5 of the CV3162-XXX may be installed in the small holes. Up to 4 of the CV3190-XXX may be installed in the large holes. )	CV3162-007	WS1 DLFC 0.7 GPM FOR 3/4	1
	CV3162-010	WS1 DLFC 1.0 GPM FOR 3/4	1
	CV3162-013	WS1 DLFC 1.3 GPM FOR 3/4	1
	CV3162-017	WS1 DLFC 1.7 GPM FOR 3/4	1
	CV3162-022	WS1 DLFC 2.2 GPM FOR 3/4	1
	CV3162-027	WS1 DLFC 2.7 GPM FOR 3/4	1
	CV3162-032	WS1 DLFC 3.2 GPM FOR 3/4	1
	CV3162-042	WS1 DLFC 4.2 GPM FOR 3/4	1
	CV3162-053	WS1 DLFC 5.3 GPM FOR 3/4	1
	CV3162-065	WS1 DLFC 6.5 GPM FOR 3/4	1
	CV3162-075	WS1 DLFC 7.5 GPM FOR 3/4	1
	CV3162-090	WS1 DLFC 9.0 GPM FOR 3/4	1
	CV3162-100	WS1 DLFC 10.0 GPM FOR 3/4	1
	CV3190-090	WS1 DLFC 9.0 GPM FOR 1	1
	CV3190-100	WS1 DLFC 10.0 GPM FOR 1	1
	CV3190-110	WS1 DLFC 11.0 GPM FOR 1	1
	CV3190-130	WS1 DLFC 13.0 GPM FOR 1	1
	CV3190-150	WS1 DLFC 15.0 GPM FOR 1	1
	CV3190-170	WS1 DLFC 17.0 GPM FOR 1	1
	CV3190-200	WS1 DLFC 20.0 GPM FOR 1	1
CV3190-250	WS1 DLFC 25.0 GPM FOR 1	1	
CV3051	WS2 DLFC NPT ASSEMBLY		

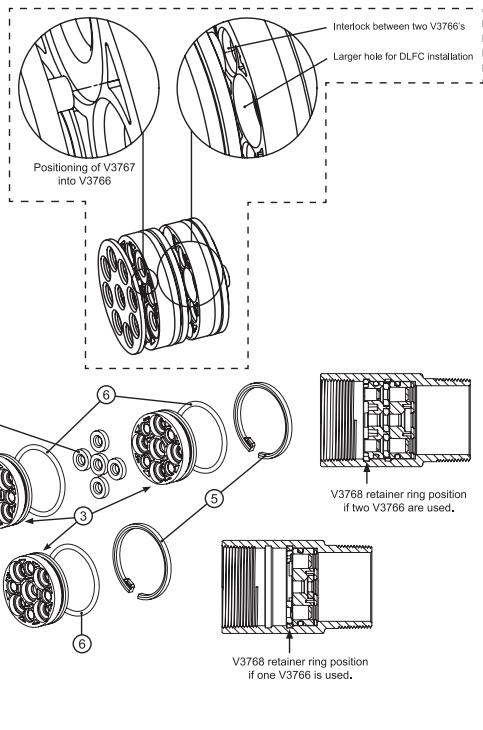
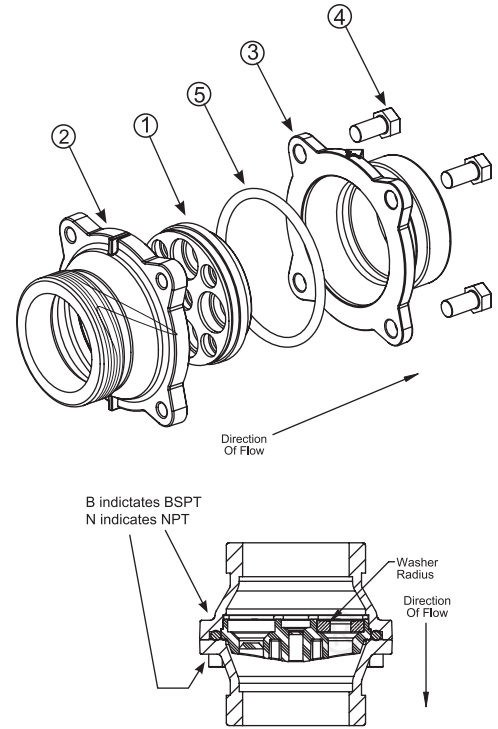

## DRAIN LINE ASSEMBLY 3"

Item #	Part #	Description	Qty.
1	CV3190-090	WS1 DLFC 9.0 GPM FOR 1	1
	CV3190-100	WS1 DLFC 10.0 GPM FOR 1	1
	CV3190-110	WS1 DLFC 11.0 GPM FOR 1	1
	CV3190-130	WS1 DLFC 13.0 GPM FOR 1	1
	CV3190-150	WS1 DLFC 15.0 GPM FOR 1	1
	CV3190-170	WS1 DLFC 17.0 GPM FOR 1	1
	CV3190-200	WS1 DLFC 20.0 GPM FOR 1	1
2	CV3765-01	WS3 DLFC HOUSING NPT	1
3	CV3766	WS3 DLFC RETAINER	1
4	CV3767	WS3 DLFC RETAINER COVER	1
5	CV3768	WS3 DLFC RETAINER RING	1
6	CV3769	O-RING, 336	1
	CV3764	WS3 DLFC NPT ASSEMBLY	

# Replacement Parts

## 1" AND 1.25" NHWP ASSEMBLIES

Item #	Part #	Description	Qty.
1	CV3073	MAV/NOWHBY COVER ASSEMBLY	1
2	CV3476	WS MOTOR ASSEMBLY, 8 FT	1
3	CV3592	SCREW, #8-3/4, PHPN T-25 SS	1
4	CV3262-01	WS1.5 & 2 ALT/2BY REDUCTION GEAR COVER ASSEMBLY	1
5	CV3110	WS1 DRIVE REDUCING GEAR 12 x 36	1
6	CV3264	WS2 BYPASS REDUCTION GEAR AXLE	1
7	CV3527	SCREW, 1/4-20 x 3/4, BHSCS SS	1
8	CV3072	MAV/NOWHBY 1/1.25/1.5 DRIVE ASSEMBLY	1
9	CV3506-01	MAV/NOHRD 1/1.25/1.5 PISTON	1
10	CV3074	MAV/NOHWPY 1/1.25/1.5 STACK ASSEMBLY	1
11	CV3521FF	NOHRD WATER BYPASS BODY ASSEMBLY F-F	1
12	CV3521FM	NOHRD WATER BYPASS BODY ASSEMBLY F-M	1
13	CV3151	WS1 NUT, QC	1
14	CV3150	WS1 SPLIT RING	1
15	CV3105	O-RING, 215	1
	CV3070FF	NO HARD WATER BYPASS 1/1.25 F-F ASSEMBLY	
	CV3070FM	NO HARD WATER BYPASS 1/1.25 F-M ASSEMBLY	

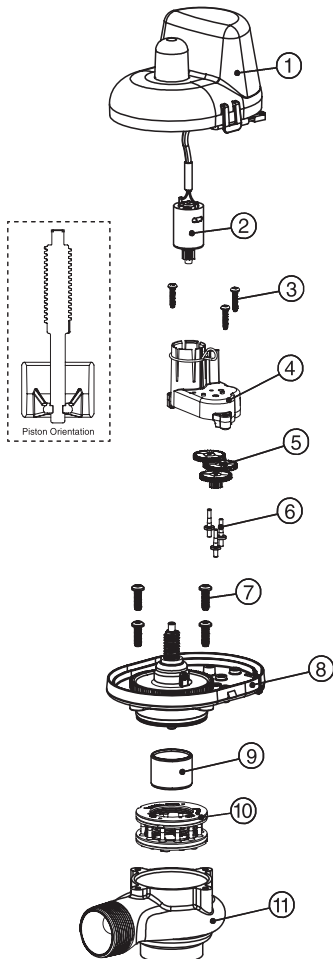
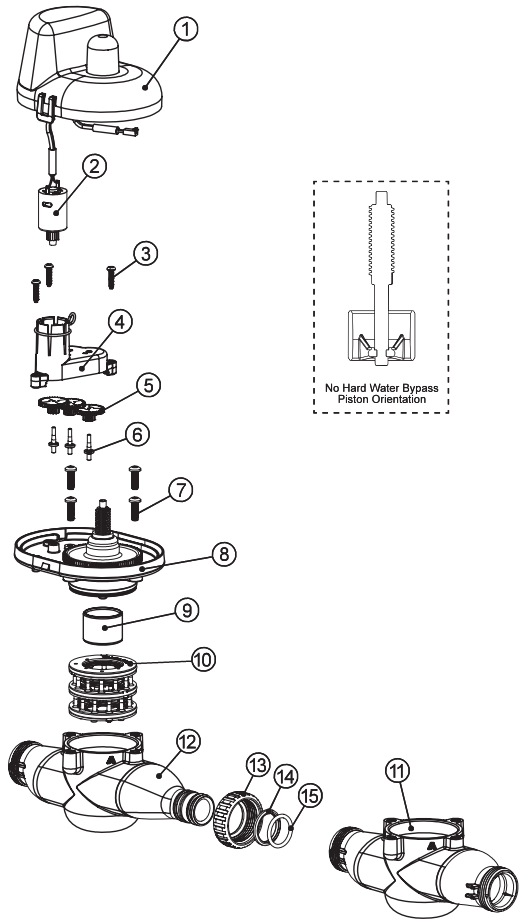

## 1.5" NHWP ASSEMBLIES

Item #	Part #	Description	Qty.
1	CV3073	MAV/NOWHBY COVER ASSEMBLY	1
2	CV3476	WS MOTOR ASSEMBLY, 8 FT	1
3	CV3592	SCREW, #8-3/4, PHPN T-25 SS	1
4	CV3262-01	WS1.5 & 2 ALT/2BY REDUCTION GEAR COVER ASSEMBLY	1
5	CV3110	WS1 DRIVE REDUCING GEAR 12 x 36	1
6	CV3264	WS2 BYPASS REDUCTION GEAR AXLE	1
7	CV3527	SCREW, 1/4-20 x 3/4, BHSCS SS	1
8	CV3072	MAV/NOWHBY 1/1.25/1.5 DRIVE ASSEMBLY	1
9	CV3506-01	MAV/NOHRD 1/1.25/1.5 PISTON	1
10	CV3886	WS15 NHWPY STACK ASSEMBLY	1
11	CV3832-01	WS15 NHWPY BODY M x F NPT	1
NOT SHOWN	CV3805	STRAIN RELIEF COVER KIT	1
	CV3097	NO HARD WATER BYPASS 1.5 M x F NPT ASSEMBLY	

# Replacement Parts

2" NHWBP ASSEMBLIES			
Item #	Part #	Description	Qty.
1	CV3073	MAV/NOHWBY COVER ASSEMBLY	1
2	CV3476	WS MOTOR ASSEMBLY, 8 FT	1
3	CV3592	SCREW, #8-3/4, PHPN T-25 SS	1
4	CV3262-01	WS1.5 & 2 ALT/2BY REDUCTION GEAR COVER ASSEMBLY	1
5	CV3110	WS1 DRIVE REDUCING GEAR 12 x 36	1
6	CV3264	WS2 BYPASS REDUCTION GEAR AXLE	1
7	CV3642	SCREW, 1/4-20 x 1-1/4, BHSCS SS	1
8	CV3078	MAV/NOHWBY 2 DRIVE ASSEMBLY	1
9	CV3634-01	MAV/NOHWBY 2 PISTON	1
10	CV3887	WS2 NHWBY STACK ASSEMBLY	1
11	CV3828-01	WS2 NHWBY BODY M x F, NPT	1
NOT SHOWN	CV3805	STRAIN RELIEF COVER KIT	1
	CV3098	MOTOR ALT VALVE 2 NPT REV2 ASSEMBLY	

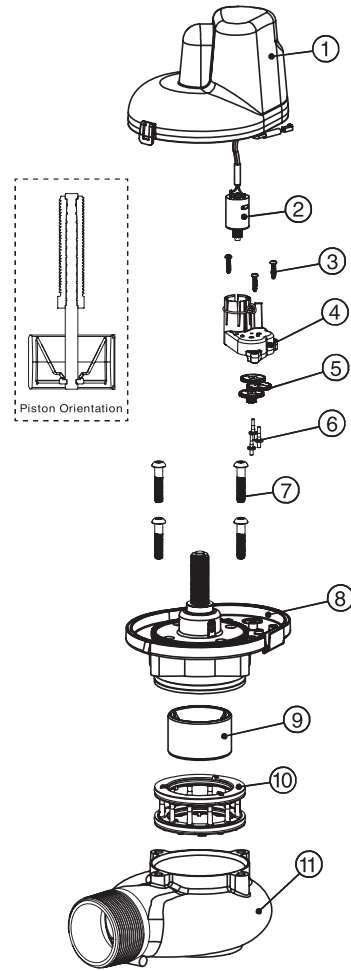

# Replacement Parts

1" AND 1.25" MAV ASSEMBLIES			
Item #	Part #	Description	Qty.
1	CV3073	MAV/NOWHBY COVER ASSEMBLY	1
2	CV3476	WS MOTOR ASSEMBLY, 8 FT	1
3	CV3592	SCREW, #8-3/4, PHPN T-25 SS	1
4	CV3262-01	WS1.5 & 2 ALT/2BY REDUCTION GEAR COVER ASSEMBLY	1
5	CV3110	WS1 DRIVE REDUCING GEAR 12 x 36	1
6	CV3264	WS2 BYPASS REDUCTION GEAR AXLE	1
7	CV3527	SCREW, 1/4-20 x 3/4, BHSCS SS	1
8	CV3072	MAV/NOWHBY 1/1.25/1.5 DRIVE ASSEMBLY	1
9	CV3506-01	MAV/NOHRD 1/1.25/1.5 PISTON	1
10	CV3074	MAV/NOHWBY 1/1.25/1.5 STACK ASSEMBLY	1
11	CV3504FF	MAV BODY 1/1.25 ASSEMBLY F-F	1
12	CV3504MM	MAV BODY 1/1.25 ASSEMBLY M-M	1
13	CV3151	WS1 NUT, QC	1
14	CV3150	WS1 SPLIT RING	1
15	CV3105	O-RING, 215	1
NOT SHOWN	CV3474	WS ALT MAV 1/1.25 CORD, 8 FT, BLACK	1
	CV3069FF	MOTOR ALT VALVE 1/1.25 F-F ASSEMBLY	
	CV3069MM	MOTOR ALT VALVE 1/1.25 M-M ASSEMBLY	

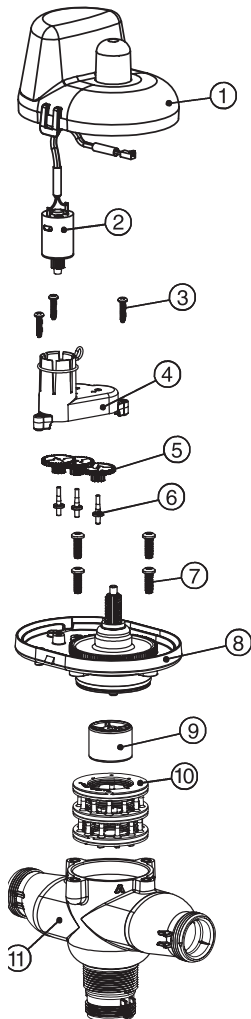

Female ports, labeled A or B, may be connected using Clack fitting packages. The motorized alternating valve unlabeled port accepts Clack fitting packages or may be removed to use 1/2" NPT threaded outlet.

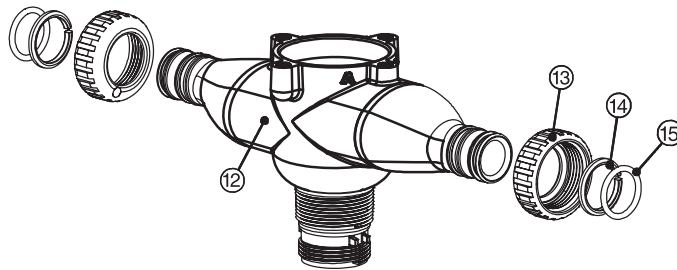

Male ports, labeled A or B, may be connected directly to a Clack 1" or 1.25" control valve outlet or to a V3191-01 vertical bypass adapter assembly. The motorized alternating valve outlet accepts Clack fitting packages or may be removed to use 1/2" NPT threaded outlet.

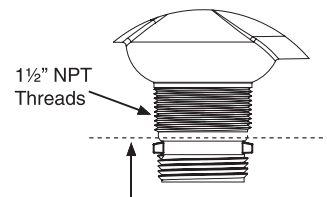
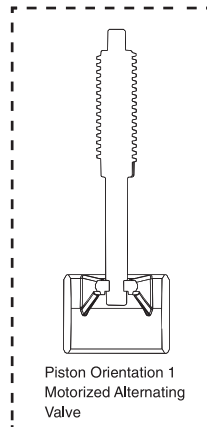

Quick Connect Nut Threads can be cut off to allow access to 1/2" NPT Threads. Deburr and clean edge after cutting.

NOTE: Teflon tape is required when using the 1/2" NPT Threads. Do not use pipe dope or other sealants on threads.

# Replacement Parts

1.5" MAV ASSEMBLIES			
Item #	Part #	Description	Qty.
1	CV3073	MAV/NOWHBY COVER ASSEMBLY	1
2	CV3476	WS MOTOR ASSEMBLY, 8 FT	1
3	CV3592	SCREW, #8-3/4, PHPN T-25 SS	1
4	CV3262-01	WS1.5 & 2 ALT/2BY REDUCTION GEAR COVER ASSEMBLY	1
5	CV3110	WS1 DRIVE REDUCING GEAR 12 x 36	1
6	CV3264	WS2 BYPASS REDUCTION GEAR AXLE	1
7	CV3527	SCREW, 1/4-20 x 3/4, BHSCS SS	1
8	CV3072	MAV/NOWHBY 1/1.25/1.5 DRIVE ASSEMBLY	1
9	CV3506-01	MAV/NOHRD 1/1.25/1.5 PISTON	1
10	CV3074	MAV/NOHWBY 1/1.25/1.5 STACK ASSEMBLY	1
11	CV3525-01	MAV BODY 1.5 NPT	1
NOT SHOWN	CV3474	WS ALT MAV 1/1.25 CORD, 8 FT, BLACK	1
	CV3071	MOTOR ALT VALVE 1.5 NPT REV2 ASSEMBLY	1
	CV3475	Option	1

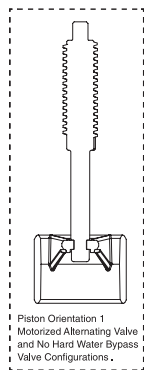
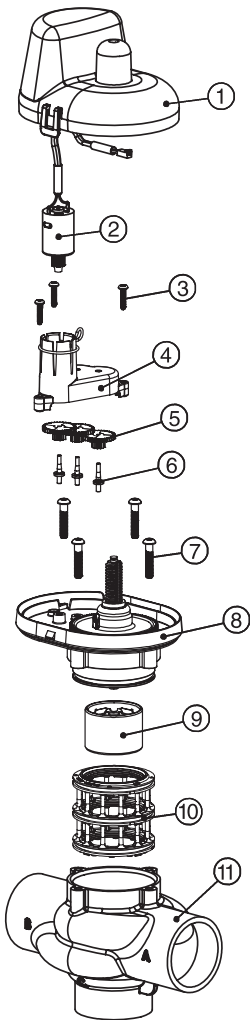
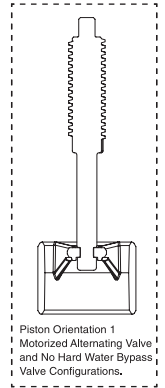
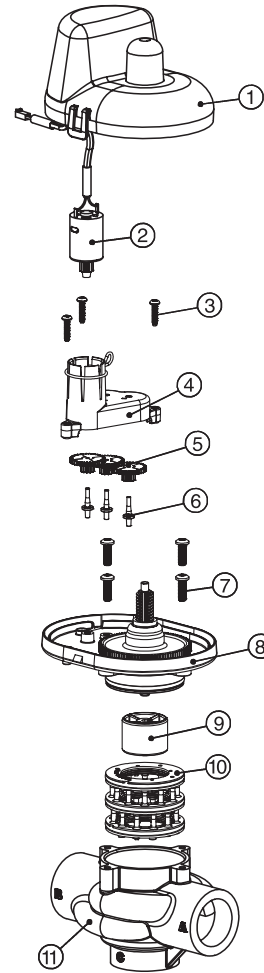

2" MAV ASSEMBLIES			
Item #	Part #	Description	Qty.
1	CV3073	MAV/NOWHBY COVER ASSEMBLY	1
2	CV3476	WS MOTOR ASSEMBLY, 8 FT	1
3	CV3592	SCREW, #8-3/4, PHPN T-25 SS	1
4	CV3262-01	WS1.5 & 2 ALT/2BY REDUCTION GEAR COVER ASSEMBLY	1
5	CV3110	WS1 DRIVE REDUCING GEAR 12 x 36	1
6	CV3264	WS2 BYPASS REDUCTION GEAR AXLE	1
7	CV3642	SCREW, 1/4-20 x 1-1/4, BHSCS SS	1
8	CV3078	MAV/NOHWBY 2 DRIVE ASSEMBLY	1
9	CV3634-01	MAV/NOHWBY 2 PISTON	1
10	CV3077	MAV/NOHWBY 2 STACK ASSEMBLY	1
11	CV3633-01	WS2 MAV BODY, NPT	1
NOT SHOWN	CV3474	WS ALT CONNECT CORD, 8 FT, BLACK	1
	CV3076	MOTOR ALT VALVE 2 NPT REV2 ASSEMBLY	1
	CV3475	Option	1

# Replacement Parts

1" PLASTIC METER ASSEMBLIES			
Item #	Part #	Description	Qty.
1	CV3003-02	WS1.5/2L/2H METER COMMERCIAL ASY	1
	CV3221	WS METER ASY 15 FT CORD (INCLUDES ITEMS 2-4)	1
2	CV3118-03	WS15/2 TURBINE ASY	1
3	CV3105	O-RING 215	1
4	CV3501	WS15/2 TURBINE CLIP	1
5	CV3755	WS1 METER HOUSING	1
6	CV3151	WS1 NUT 1 QC	1
NOT SHOWN	CV3756	WS1 FLOW STRAIGHTENER	1
	CV3039-15	ASSEMBLY	

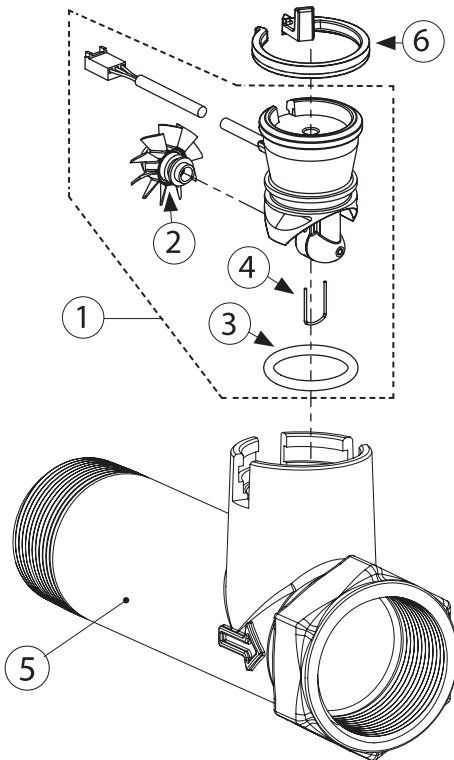
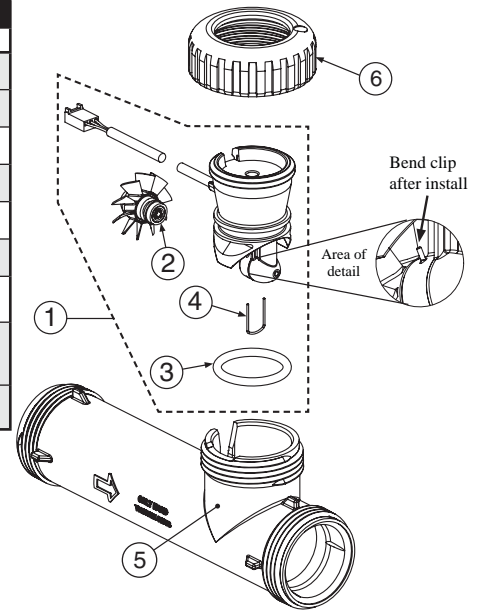

1.5", 2", 3" STAINLESS STEEL METER ASSEMBLIES			
Item #.	Part #	Description	Qty.
1	CV3003-02	WS1.5/2L/2H METER COMMERCIAL ASY	1
	CV3221	WS METER ASY 15 FT CORD (INCLUDES ITEMS 2-4)	1
2	CV3118-03	WS15/2 TURBINE ASY	1
3	CV3105	O-RING 215	1
4	CV3501	WS15/2 TURBINE CLIP	1
5	CV3401-04	WS15 METER HOUSING	1
	CV3754-01	WS2 METER HOUSING	1
	CV3601-01	WS3 METER HOUSING	1
6	CV3632	METER RETAINING CLIP	1
	CV3040-15	WS1.5 COMPLETE METER ASSEMBLY	
	CV3094-15	WS2 COMPLETE METER ASSEMBLY	
	CV3095-15	WS3 COMPLETE METER ASSEMBLY	

# Replacement Parts

BRINE TANK ASSEMBLY			
Item #	Current Part #	Description	Qty.
1	100379336	19" x 37" Brine tank	1
2	100379337	Brine tank lid	1
3	100379338	Brine well	1
4	100399465	Safety shutoff assembly, 0.5 gpm	1
5	100245864	Safety shutoff nut	1
6	100379339	Brine well cover	1
7	100397461	Brine well retainer	1
8	100238195	Cabinet overflow elbow	1

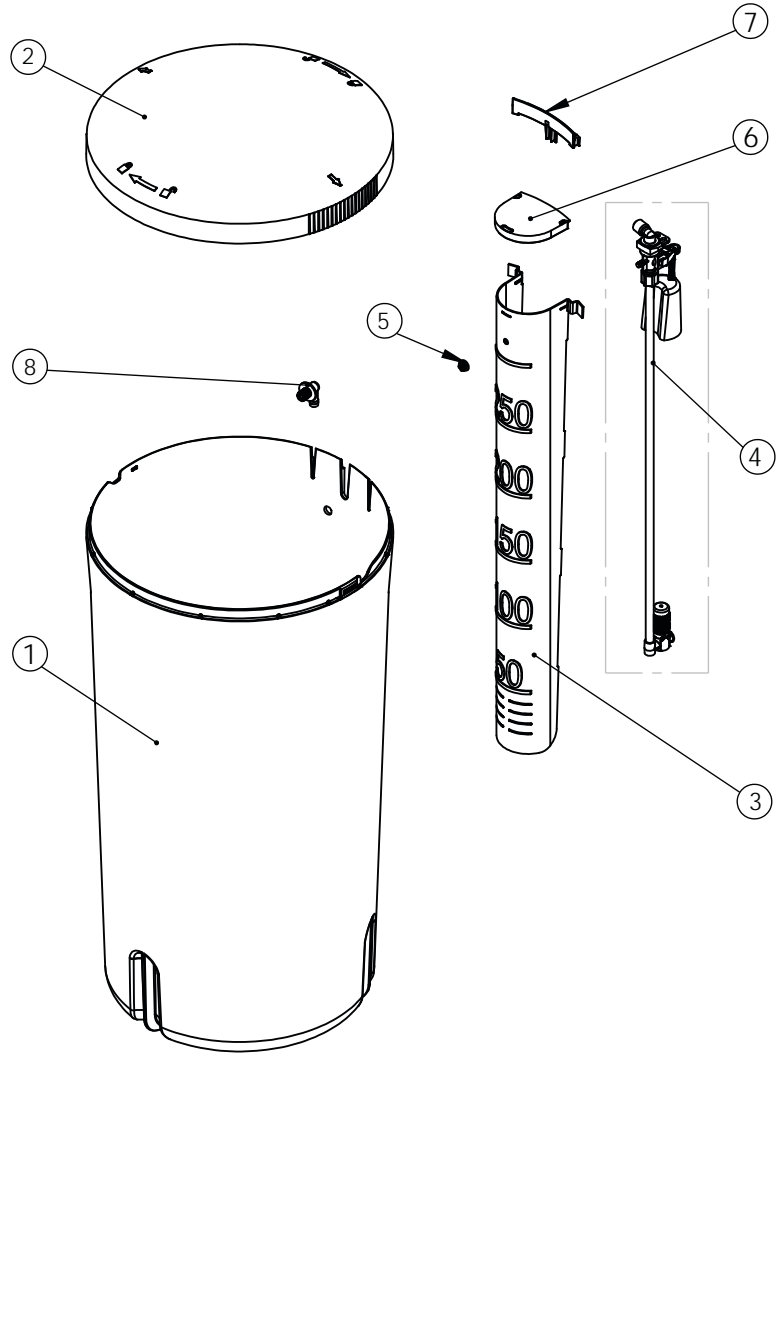

SAFETY FLOAT BRINE ELBOW				
Item #	Legacy Part #	Current Part #	Description	Qty.
	CV4144	100245015	3/8" elbow cap, Parker fitting (no flow control)	1
	CV4144-03	100242646	3/8" elbow cap, Parker fitting (w/flow control)	1
	CH4612	100245861	1/2" elbow cap	1

# Replacement Parts

BRINE TANK ASSEMBLIES		
Part #	Description	Qty.
AOBT1937-1A	19x37 BRINE TANK ASSEMBLY	1
BT1840-1A	18x40 BT ASSY 3/8 BRINE LINE	1
BT1840-2A	18x40 BT ASSY 1/2 BRINE LINE	1
BT2441-1A	24x41 BT ASSY 3/8 BRINE LINE	1
BT2441-2A	24x41 BT ASSY 1/2 BRINE LINE	1
BT2450-1A	24x50 BT ASSY 3/8 BRINE LINE	1
BT2450-2A	24x50 BT ASSY 1/2 BRINE LINE	1
BT3050-2A	30x50 BT ASSY 1/2 BRINE LINE	1
BT3050-3A	30x50 BT ASSY 3/4 OR 1 BRINE CONNECTION	1
BT3948-2A	39x48 BT ASSY 1/2 BRINE LINE	1
BT3948-3A	39x48 BT ASSY 3/4 OR 1 BRINE CONNECTION	1
BT5060-2A	50x60 BT ASSY 1/2 BRINE LINE	1
BT5060-3A	50x60 BT ASSY 3/4 OR 1 BRINE CONNECTION	1

INTERNAL BRINE TANK ASSEMBLIES (INCLUDES SAFETY FLOAT, BRINE LINE, WELL & CAP, OVERFLOW)		
Part #	Description	Qty.
BT1840-1-GUTS	18x40 BRINE TANK INTERNAL ASSY KIT 3/8"	1
BT1840-2-GUTS	18x40 BRINE TANK INTERNAL ASSY KIT 1/2"	1
BT2441-1-GUTS	24x41 BRINE TANK INTERNAL ASSY KIT 3/8"	1
BT2441-2-GUTS	24x41 BRINE TANK INTERNAL ASSY KIT 1/2"	1
BT2450-1-GUTS	24x50 BRINE TANK INTERNAL ASSY KIT 3/8"	1
BT2450-2-GUTS	24x50 BRINE TANK INTERNAL ASSY KIT 1/2"	1
BT3050-2-GUTS	30x50 BRINE TANK INTERNAL ASSY KIT 1/2"	1

BRINE TANK COMPONENTS		
Part #	Description	Qty.
CH4700-36.5WR-1	SAFTEY SHUT BRINE ASSY W/ FLOAT AND AIR CHECK 3/8 18X40 AND 24X41 BT	1
CH4600-50	474 SAFTEY SHUT OFF 3/8" ELBOW	1
CH4600-02	474 SAFTEY SHUT OFF 1/2" ELBOW	1
CH4500-48	474 AIR CHECK 1/2" X 48"	1
CH4900	494 BRINE ASSY 3/4" OR 1" ELBOW	1
CH1030-36S	SLOTTED BRINE WELL 4"X36"	1
CH7016	4" BRINE WELL COVER	1
CH1033-48S	SLOTTED BRINE WELL 5"X48"	1
CH1017	5" BRINE WELL COVER	1
CH4640-32	474 FLOAT ASSY W/ 2 GROMMETS	1
CH1018	2 PIECE OVERFLOW SET	1
CH1072-01	18" GRID PLATE	1
CH1080	24" GRID PLATE SET	1
CH1032	30" GRID PLATE SET	1
BSA-3923-05*	39" GRID PLATE ASSY	1

\*Contact Technical Service for specific build.

SAFETY FLOAT BRINE ELBOW		
Part #	Description	Qty.
CH4651-050	474 .5 gpm flow control	1
CV3163	O-Ring 019	1
CV4144	3/8" elbow cap, Parker fitting	1
CH4612	1/2" elbow cap	1
CH4615	Elbow locking clip	1
CH4612	Regenerant Elbow with Flow Control	1
CJCPG-8PBLK	Nut, Compression 1/2" Black	1

# Installation Fitting Assemblies

**NOTE: Not all available fittings are displayed below. Contact manufacturer for optional fittings.**

For All Assemblies

Item No.	Part No.	Description	Qty.
1	CV3151	Nut, 1" quick connect	2
2	CV3150	Split ring	2
3	CV3105	O-ring 215	2

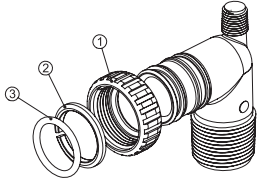

1" PVC MALE NPT ELBOW			
Item	Part No.	Description	Qty.
	CV3007	1" PVC male NPT elbow assembly	2
4	CV3149	Fitting	2

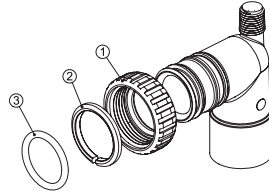

3/4" & 1" PVC SOLVENT ELBOW			
Item	Part No.	Description	Qty.
	CV3007-01	3/4" & 1" PVC solvent elbow assembly	2
4	CV3189	Fitting	2

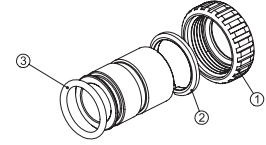

1" BRASS SWEAT			
Item	Part No.	Description	Qty.
	CV3007-02	1" brass sweat assembly	2
4	CV3188	Fitting	2

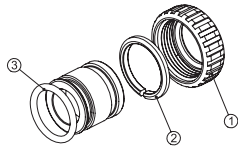

3/4" BRASS SWEAT			
Item	Part No.	Description	Qty.
	CV3007-03	3/4" brass sweat assembly	2
4	CV3188-01	Fitting	2

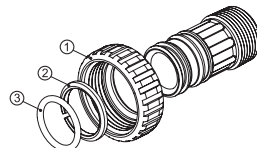

1" PLASTIC MALE NPT			
Item	Part No.	Description	Qty.
	CV3007-04	1" plastic male NPT assembly	2
4	CV3164	Fitting	2

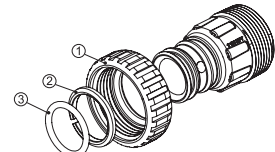

1-1/4" PLASTIC MALE NPT			
Item	Part No.	Description	Qty.
	CV3007-05	1-1/4" plastic male assembly	2
4	CV3317	Fitting	2

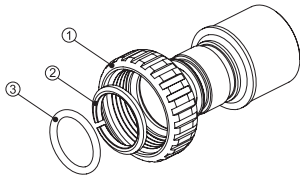

1-1/4" & 1-1/2" BRASS SWEAT			
Item	Part No.	Description	Qty.
	CV3007-09	1-1/4" & 1-1/2" brass sweat assembly	2
4	CV3375	Fitting	2

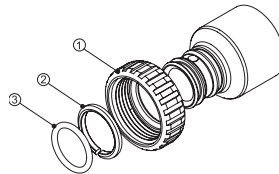

1-1/4" & 1-1/2" PVC SOLVENT			
Item	Part No.	Description	Qty.
	CV3007-07	1-1/4" & 1-1/2" PVC solvent assembly	2
4	CV3352	Fitting	2

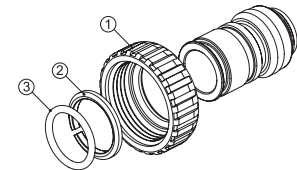

3/4" BRASS SHARK BITE			
Item	Part No.	Description	Qty.
	CV3007-12	3/4" brass shark bite assembly	2
4	CV3628	Fitting	2

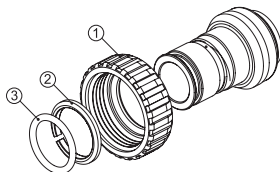

1" BRASS SHARK BITE			
Item	Part No.	Description	Qty.
	CV3007-13	1" brass shark bite assembly	2
4	CV3629	Fitting	2

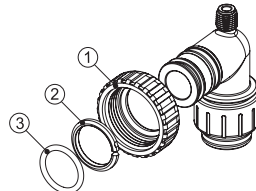

3/4" JOHN GUEST ELBOW			
Item	Part No.	Description	Qty.
	CV3007-15	3/4" john guest elbow assembly	2
4	CV3790	Fitting	2

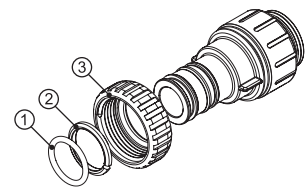

1" JOHN GUEST			
Item	Part No.	Description	Qty.
	CV3007-17	1" john guest assembly	2
4	CV4045	Fitting	2

*This page intentionally left blank.*

# A. O. Smith Commercial Limited Warranty

## WHO IS COVERED

This limited warranty is provided by A. O. Smith and applies only to the original owner who purchased and installed the A. O. Smith product for use at the original installation site. This warranty is non-transferable.

## WHAT IS COVERED

This warranty covers defects in materials or workmanship in your A. O. Smith product when properly installed, used under normal operating conditions, and maintained according to A. O. Smith guidelines and local plumbing codes.

## WARRANTY COVERAGE PERIODS

All warranty coverage periods run from the date of purchase, or 60 days after the date of manufacture if the purchase date cannot be verified.

**For a period of FIVE YEARS:** The control valve and all internal components.

The salt storage container.

Fiberglass mineral tank except damages due to freezing, high pressure (120 psi and above), extreme temperature (100°F and above) or a vacuum on the system.

**For a period of ONE YEAR:** All other softener components.

This warranty does not cover any equipment purchased for use in applications in which the product is not suited. It is the responsibility of the buyer to determine if a product is suitable for a particular application.

## WHAT A. O. SMITH WILL DO

If a component is found defective during its warranty period, A. O. Smith will repair or replace the defective part at its discretion with an identical part or a comparable part if an identical replacement is not available. The owner is responsible for freight charges from the factory and local dealer service or labor fees. The warranty period for any replacement will run for the balance of the original warranty period.

## WHAT A. O. SMITH WILL NOT DO

A. O. Smith will not pay for labor to remove or reinstall parts, shipping damage, water damage resulting from system failure, dealer trip charges, unauthorized service, damage caused by failure to follow installation instructions, or replacement filters, media, or routine maintenance.

## WHAT IS NOT COVERED

1. This warranty does not cover: damage caused by accident, misuse, neglect, fire, flood, freezing, or other acts of God, improper installation, alteration, vacuum damage, chemicals, operation outside specifications, cosmetic issues, non-A. O. Smith parts, installation costs, improper plumbing connections, lack of maintenance, use with water that is microbiologically unsafe, loss of use, property damage, incidental or consequential damages, freight, or water damage. A. O. Smith disclaims all implied warranties to the fullest extent permitted by law.
2. Except when specifically prohibited by the applicable state law, the Owner, and not the Manufacturer, shall be liable for and shall pay for all charges for labor or other expenses incurred in the removal, repair or replacement of any component part(s) claimed to be defective or any expense incurred to remedy any defect in the product. Such charges may include, but are not necessarily limited to:
  - a. All freight, shipping, handling and delivery costs of forwarding a new component or replacement part(s) to the owner.
  - b. All costs necessary or incidental in removing the defective component part(s) and installing a new component part(s).
  - c. Any material required to complete, and/or permits required for, installation of a new component or replacement part(s).
  - d. All costs necessary or incidental in returning the defective component part(s) to a location designated by the Manufacturer.
  - e. This warranty provides specific legal rights and limitations, but you may have other rights under applicable state law.

## OWNER RESPONSIBILITIES

Owners must install and operate the system per A. O. Smith specifications, comply with local codes, prevent freezing or vacuum damage, operate within pressure/temperature limits, replace media/filters as required, use only approved components, and retain proof of purchase and installation date. Either proof of purchase from an authorized dealer or proof of serial number, along with proof of proper installation, will be required to obtain warranty coverage.

## HOW TO OBTAIN SERVICE

If service is required, contact your installation dealer or an authorized A. O. Smith dealer. If unavailable, ship the defective component (freight prepaid) to: **A. O. Smith, 1000 Prospect Ct., Appleton, WI 54914**. A. O. Smith will return repaired or replaced parts freight collect. Registration is not required to be covered by this warranty.

## LIMITATION OF REMEDIES

The owner's sole remedy is repair or replacement of defective parts. A. O. Smith is not liable for incidental, consequential, water, or property damages. Some states do not allow such limitations; in such states, these may not apply.

## STATE LAW RIGHTS

This warranty provides specific legal rights; additional rights may vary by state.

*This page intentionally left blank.*

*This page intentionally left blank.*



1900 Prospect Court • Appleton, WI 54914  
Phone: 920-739-9401 • Fax: 920-739-9406

